

Wireless Communications Technologies
16:332:559 (Advanced Topics in Communications)
Lecture 25 (April 30th) and Lecture 26 (May 1st)
Instructor: Professor Narayan Mandayam
Summarized by: Steve Leung (leungs@ece.rutgers.edu)

Lecture 25

Resource Allocation Algorithm

To assign for each mobile

- a) An access port from set B
- b) A channel pair from set C
- c) A transmitter power for RAP & MS such that all assigned links meet their minimum SIR requirement

Link gain matrix $G=(G_{ij})$

What is optimum?

Define $Y = \#$ of mobiles from M total mobiles that have an adequate link.

Optimum \rightarrow maximize Y for a given G

To handle the stochastic nature of a system

$M \rightarrow$ random variable

$Y \rightarrow$ random variable

Let $Z = M - Y$

Define "assignment failure rate" as

$$\nu = \frac{E[Z]}{E[M]}$$

Measure of average portion of mobiles allocated a link of adequate quality.

Usually model mobiles that are active as a 2-D Poisson point process with arrival rate w (unit of mobiles/unit area)

If A is the service area, then $E[M]=wA$

$$\nu = \frac{E[Z]}{wA}$$

For large w , ν is also a good approximation of the probability that a randomly chosen active mobile at some given instant is not provided with a channel.

Define: Instantaneous capacity of a wireless system

$$w^*(\nu_o) = \{\max w : \nu \leq \nu_o\}$$

i.e. max allowed traffic load in order to keep assignment failure rate below some threshold ν_o

Satisfying above criteria is not practical. Try different ideas & see how it compares to above.

Channel assignment in literature based on simple heuristic ideas/design rules

Fixed Channel Allocation (FCA)

Fixed reuse and assignment sectorization & directional antennas.

Assume available channels in cellular system are grouped into channel groups numbered 1,2,3,...,k & let D be the minimum reuse distance.

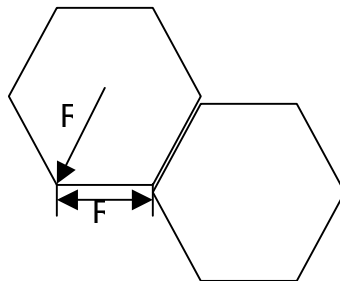

For hexagonal geometry and fully symmetric cell plans

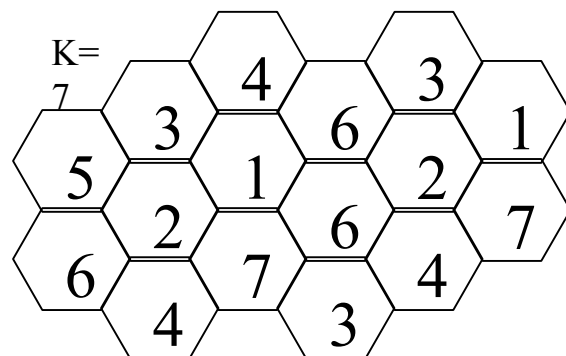
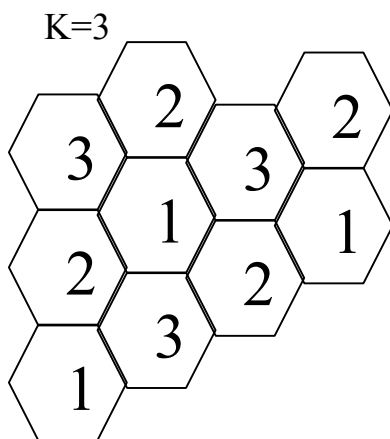

Each cell has six nearest neighbors all at same (min) reuse distance D .

In this case, the following relationship holds

$$\Delta = \frac{D}{R} = \sqrt{3K} \text{ normalized reuse distance}$$

It can be shown that there exists fully symmetric cell plans for all integers k that can be written in the following form

$$k = (i + j)^2 - ij \text{ for } i, j = 0, 1, 2, 3, \dots$$

possible values of $k = \{1, 3, 4, 7, 9, 12, 13, \dots\}$ (see Don C. Cox "Co-channel interference considerations in frequency reuse small coverage radio systems" IEEE Transactions on Communications volume 30 number 1, 1982)

Dynamic Channel Allocation (DCA)

(1) **Traffic adaptive DCA** – adapt allocation of spectral resources among cells according to current # of active mobiles in each cell.

Using a worst-case design, propagation conditions in your cellular system may be very "roughly" described using the "cell compatibility" concept. For any pair of cells, the worst case design ensures either interference free operation or not.

Define compatibility matrix I with elements

$$I_{i,j} = \begin{cases} 1, & \text{if active link in cell } i \text{ interferes with active link in cell } j \\ 0, & \text{otherwise} \end{cases}$$

Two cells i & j are *not* compatible if $i, j = 1$. Cell i & cell j may not use a common channel.

Optimum traffic after channel allocation scheme is one that minimized assignment failure rate $Z \rightarrow$ maximum packing (MP) schemes

Policy: A new call will be blocked only if there's no possible channel allocation to calls that would result in room for the new call \rightarrow strategy to find the minimum # of channels to carry instantaneous existing calls.

Use graph theory.

Define a "node" as a cell (RAP) and an edge as a compatibility constraint. A cellular network can be represented by a graph.

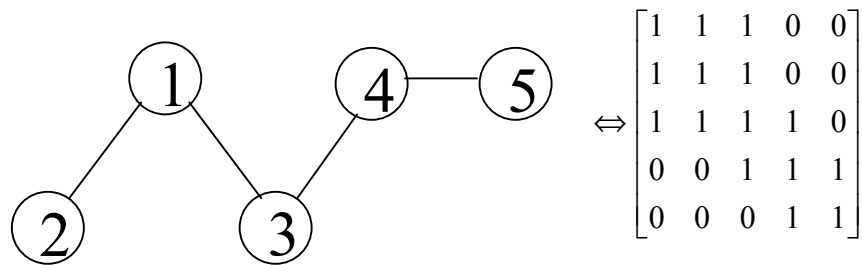

If 2 cells i & j are not compatible, then there is an edge connecting the nodes. For multiple users/cell, duplicate node as many times as # of users in that cell and connect the edges.

Graphical \rightarrow MP (graph coloring problem color = channels, any 2 nodes cannot have same color) interpreted as minimizing # of colors that fill every node in a way that 2 adjacent connected nodes cannot be colored in the same color.

“graph coloring problem” \rightarrow NP complete (no algorithm to finish in polynomial time), in practice \rightarrow MP provides performance bound.

Reality \rightarrow use heuristic schemes \rightarrow use different allocations of channels/cell according to traffic patterns & historical data.

(2) Reuse Partitioning DCA

Use overlaid cell plans (reuse distances) with different reuse distances (idea based on MS close to RAP can tolerate lower reuse than MS @ edge of cell)

(3) Interference based DCA Schemes

Includes strategies for channel searching & prediction of interference levels.

Not conservative or pessimistic. A simple distributed dynamic channel algorithm based on estimated SIR. Initially a terminal is using channel ‘ j ’

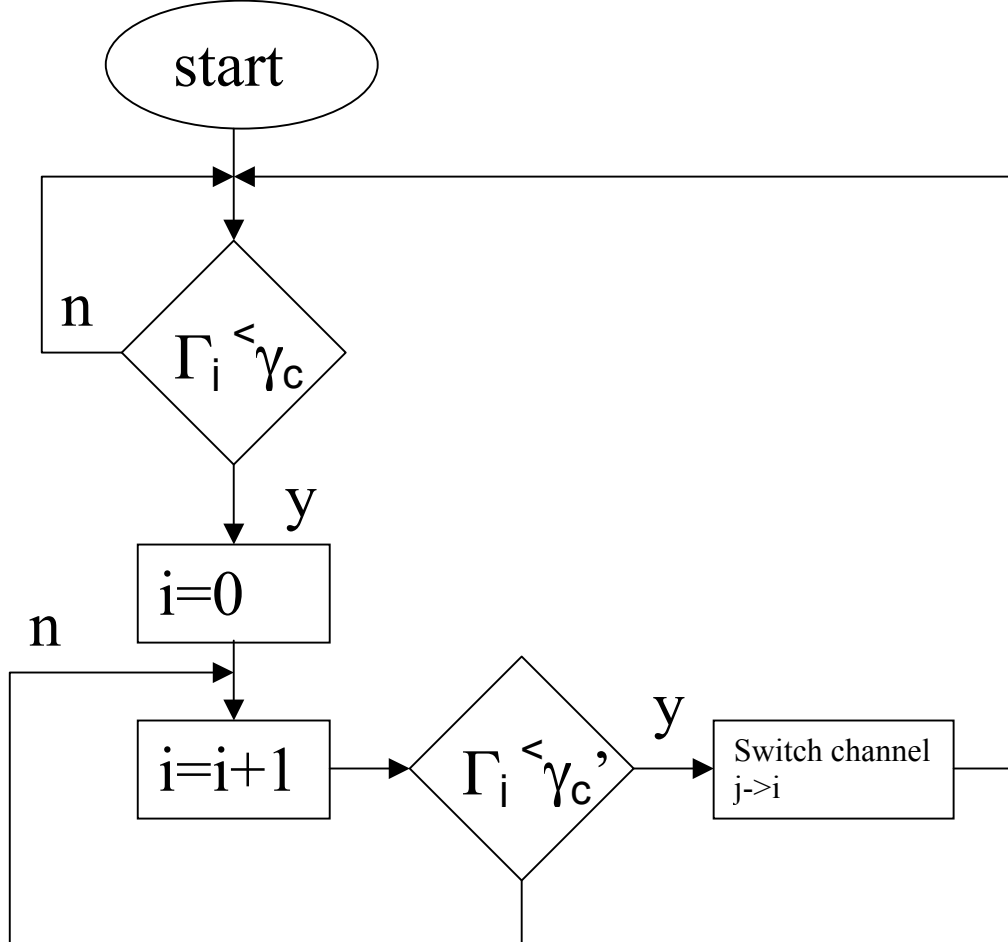

Performance depends on choice of γ_c & γ_c'

Typically select γ_c to be higher than γ_0 (actual requirement)

γ_c' -> using high value of this reduces the risk of avalanche of channel changes.

Lecture 26

Transmitter power control

Let us consider a channelized system. Let mobile 'i' communicate with RAP 'i' on some channel.

The SIR of MS i at RAP i

$$\gamma_i = \frac{G_{ii}P_i}{\sum_{j \neq i} G_{ij}P_j + N}$$

G_{ij} , BS i, mobile j

Let $\frac{P}{P_i} = (P_1, P_2, \dots, P_Q)^T$ -> non-negative $P_j \geq 0 \forall j = 1 \dots Q$

$$\gamma_i = \frac{P_i}{\sum_{j \neq i} P_j \frac{G_{ij}}{G_{ii}} + \frac{N}{G_{ii}}} = \frac{P_i}{\sum_{j=1}^Q P_j Z_{ij} - P_i + N'_i} \quad \text{Yens Zander 1992 KPH Sweden}$$

$$\text{Normalized link gain } Z_{ij} = \frac{G_{ij}}{G_{ii}} + N'_i = \frac{N_i}{G_{ii}}$$

Define matrix $Z=(Z_{ij})$

We require $\gamma_i \geq \gamma_0 \forall i$, not possible to satisfy this all the time

Define: The SIR γ_0 is "achievable" if exists a non-negative \underline{P} such that $\gamma_i \geq \gamma_0 \forall i$

$$\text{In matrix form } \left(\frac{1+\gamma_0}{\gamma_0} I - Z \right) \underline{P} \geq \underline{N}'$$

Each component of LHS \geq each component of RHS

If the system of linear inequalities has some solution with $\underline{P} \geq \underline{0}$, then the SIR γ_0 achievable.

Theorem: (noiseless case) The inequality $\left(\frac{1+\gamma_0}{\gamma_0} I - Z \right) \underline{P} \geq \underline{0}$ has a solution in \underline{P}

$$\geq \underline{0} \text{ iff } \gamma_0 \leq \frac{1}{\lambda^* - 1} = \gamma^*$$

Where λ^* is the dominant (maximum) Eigenvalue (Peron-Frobenius theorem) of the matrix Z .

The power vector satisfying the expression with equality & thus achieving the largest SIR is \underline{P}^* , the eigenvector corresponding to Eigenvalue λ^* .

\underline{P}^* achieves γ^* at all links -> *SIR balanced system* corollary (noise included). The inequality $\left(\frac{1+\gamma_0}{\gamma_0} I - Z \right) \underline{P} \geq \underline{N}'$ has solutions in $\underline{P} \geq \underline{0}$ if $\gamma^* > \gamma_0$, where $\gamma^* = \frac{1}{\lambda^* - 1}$

Distributed Power Control (based on SIR balancing)

Powers of users according to

$$P_i^{(n+1)} = P_i^{(n)} \frac{\gamma^*}{\gamma_i^{(n)}} \forall i = 1, 2, \dots, Q, \text{ where } i=\text{user}, n=\text{iteration}, \gamma^*=\text{target}, \gamma_i^{(n)}=\text{SIR}$$

achieved @ step n

Convergence: Algorithm converges as long as the set of powers all remain feasible (i.e. SIR γ_0 is achievable)

Synchronous -> Foschini & Miljanic 1993

Asynchronous -> Mitra 1993

The above results on distributed power control assume (implicitly) a fixed base station assignment

Minimum Power Assignment (Can be thought of as generalization of soft hand-offs) At each step of the iterative procedure, a user is assigned to the base station at which its SIR is maximized. (The objective here is to minimize sum of total transmit powers in the system).

Convergence: For continuous adjustments Yates & Huang 1995, Hanly 1995

For discrete adjustments Stolyar & Fleming, Song & Mandayam 2000

Macro Diversity – Combining of received signals of a user at all base stations (at least more than one) (Hanly, 1993)

Therefore SIR is the sum of SIRs at different base stations (reminiscent of MRC)

Multiple Connection Reception: User required to maintain acceptable SIR at more than one base station.

Unified Framework for Uplink Power Control

Yates (1995) formulated unified framework for power control for distributed uplink power control & its convergence. All the above classes of power control algorithms can be viewed to be of the form

$$\underline{P} \geq \underline{I}(\underline{P}) = (I_1(\underline{P}), I_2(\underline{P}), I_3(\underline{P}), \dots, I_N(\underline{P})), \text{ where } \underline{I}() \text{ is the interference function}$$

$I_j(\underline{P})$ =effective interference of other users that user j must overcome.

In other words, if $P_j > I_j(\gamma)$ then user j has an acceptable connection

All iterative power control algorithms are of the form

$$\underline{P}(t+1) = \underline{I}(\underline{P}(t)), \text{ where } t \text{ is the iteration index}$$

Any algorithm of the above form will converge as long as $\underline{I}(\underline{P})$ is a “standard interference function”

i.e. it satisfies the following properties

- Positivity $I(P) \geq 0$.
- Monotocity if $P > P'$, then $I(P) > I(P')$
- Scaleabitliy for all $\alpha > 1$, $\alpha I(P) > I(\alpha P)$

The result assumes that the system is feasible. Easy to show that fixed assignment is minimum power assignment. Macro diversity & multiple connections are all standard. i.e. the respective interference function are all standard.

Power Control in Practice

In practice power updates occur in discrete steps. In IS-95 “inner loop” power control adjusts power 800x/sec in steps of $\pm\Delta\text{dB}$, where $\Delta=0.5$ or 1. “Outer loop” controls SIR *target* whenever the system encounters infeasibility. 3G (WCDMA) “inner loop” updates are 1600x/sec.

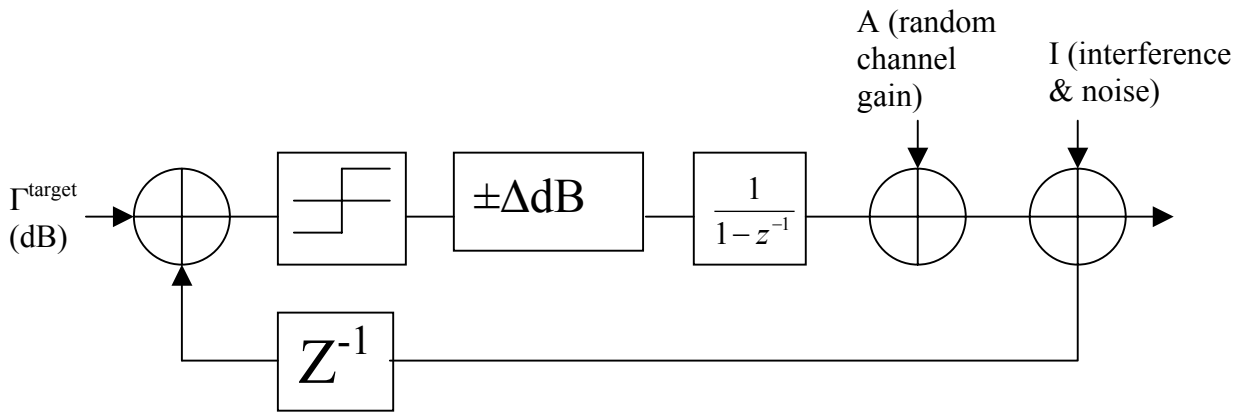

“Outer loop” operates on a slower timescale where Γ^{target} is adjusted. Song-Mandayam-Gajic IEEE JSAC Feb. 2001.

Analysis via “statistical linearization” study stability & convergence.