

# SMACK - A SMart ACKnowledgment Scheme for Broadcast Messages in Wireless Networks

Aveek Dutta<sup>1</sup>, Dola Saha<sup>2</sup>, Dirk Grunwald<sup>1,2</sup>, Douglas Sicker<sup>2</sup>

<sup>1</sup>Department of Electrical, Computer and Energy Engineering

<sup>2</sup>Department of Computer Science

University of Colorado

Boulder, CO 80309-0430 USA

{Aveek.Dutta, Dola.Saha, Dirk.Grunwald, Douglas.Sicker}@colorado.edu

## ABSTRACT

Network protocol designers, both at the physical and network level, have long considered interference and simultaneous transmission in wireless protocols as a problem to be avoided. This, coupled with a tendency to emulate wired network protocols in the wireless domain, has led to artificial limitations in wireless networks.

In this paper, we argue that wireless protocols can exploit *simultaneous transmission* to reduce the cost of reliable multicast by **orders of magnitude**. With an appropriate application interface, simultaneous transmission can also greatly speed up common group communication primitives, such as anycast, broadcast, leader election and others.

The proposed method precisely fits into the domain of directly reachable nodes where many group communication mechanisms are commonly used in routing protocols and other physical-layer mechanisms. We demonstrate how simultaneous transmission can be used to implement a *reliable broadcast* for an infrastructure and peer-to-peer network using a prototype reconfigurable hardware. We also validate the notion of using simple spectrum sensing techniques to distinguish multiple transmissions. We then describe how the mechanism can be extended to solve group communication problems and the challenges inherent to build innovative protocols which are faster and reliable at the same time.

## Categories and Subject Descriptors

C.2.2 [COMPUTER-COMMUNICATION NETWORKS]: Network Protocols—*Protocol Verification*; C.3 [SPECIAL-PURPOSE AND APPLICATION-BASED SYSTEMS]: Signal Processing Systems

## General Terms

Design, Performance, Verification

## Keywords

Software Defined Radio, Orthogonal Frequency Division Multiplexing

Permission to make digital or hard copies of all or part of this work for personal or classroom use is granted without fee provided that copies are not made or distributed for profit or commercial advantage and that copies bear this notice and the full citation on the first page. To copy otherwise, to republish, to post on servers or to redistribute to lists, requires prior specific permission and/or a fee.

SIGCOMM'09, August 17–21, 2009, Barcelona, Spain.

Copyright 2009 ACM 978-1-60558-594-9/09/08 ...\$10.00.

## 1. INTRODUCTION

Noise and interference are fundamental aspects of communications, and are exceptionally important for wireless communications because it's more difficult to contain propagation without waveguides such as wires and fibers. Avoiding interference or noise is a fundamental design objective that limits the scope of simultaneous multi-user communication. Conventional single carrier communication focuses on decoding the strongest signal while discarding anything else as noise or interference.

Multi-user communication requires some form of *orthogonal channel* for modulation that allows multiple parties to communicate simultaneously. There are a number of ways to implement orthogonal channels - code division multiple-access (CDMA) has been adopted as a very reliable multiple access techniques by using specially designed *codes* with strong auto-correlation properties. With spatial frequency reuse, frequencies are allocated in a way such that signals from far away communicating pairs will be so strongly attenuated that they won't interfere in local communication. Time division multiplexing, or taking turns using a channel, is another method.

In this paper, we focus on using *orthogonal frequency division modulation* (OFDM) to provide distinct orthogonal signals. OFDM is a mechanism that splits the available spectrum into a number of orthogonal non-interfering *subchannels*. Being orthogonal, each of the subcarriers can be treated as an information carrying medium without significant interference with another subcarrier. Variants of the OFDM waveform are used in a number of current wireless (and wired) physical layers, including the 802.11a/g. Under OFDM, different nodes can also communicate on different *subcarriers*, as used in WiMax, which employs "scalable OFDMA" where users use different subcarriers or set of subcarriers to transmit data over the same medium and at the same carrier frequency.

The ability to distinguish multiple simultaneous transmissions requires either the signal structure to be fairly simple or the decoding/detection mechanism to be complex. In this paper we focus on a set of network primitives that calls for a very simple answer typically in binary; in the form of *yes or no*. Empowered by subcarrier transmission using OFDM we can either transmit a 1 or a 0 to convey these binary answers. Not only is this form of signaling simple, the detection of such a multiuser communication can be accomplished using spectrum sensing and energy detection. Simultaneous transmissions can be an advantage in a number of network applications that call for multiple nodes to participate and also use simple information. Examples include route requests, leader election, network management and other operations involving broadcast or multicast messages. Not only does simultaneous

transmission make the message exchange faster, it also allows such exchanges to be reliable.

To demonstrate that the complexity in implementing this form of multiuser communication is indeed tractable, we implemented the protocol in a prototype hardware platform. Using FPGA based Software Defined Radios (SDR) we demonstrate the ability to detect multiple tone transmissions using Fourier transform and energy detection. The contributions of this paper are:

- We describe the practical constraints on using simultaneous communication for a wireless mesh network.
- We describe how simultaneous reception can be used to greatly improve protocol performance.
- We demonstrate the practicality of the system using a Software Defined Radio implementation of our protocol.

The rest of the paper is organized as follows. Section §2 provides some background theory on OFDM signal structure and its relation to Fourier transform. Section §3 explains the protocol functionality and its efficiency. Section §4 describes the robustness of the protocol. In section §5 we present the challenges and issues involved in implementing the protocol using SDRs. This is followed by the actual hardware implementation and design aspects in section §6. To evaluate the hardware and the protocol performance we present a set of experiments in section §7. The results from the experiments have been analyzed in §8. To demonstrate the usefulness of this physical layer protocol to higher layer protocols we present a few applications in §10. Prior work related to this paper has been investigated in section §11. Finally we conclude the paper in §12.

## 2. OFDM AND FOURIER TRANSFORM

Orthogonal Frequency Division Multiplexing (OFDM) [6] is a special type of Multicarrier Modulation (MCM), where the data stream is divided into several bit streams and the modulated subcarriers are spaced closely, although overlapping in such a manner that they do not interfere with each other. Using the Fourier Transform and its inverse, the signal is efficiently converted from the time domain to the frequency domain and vice versa. Even though the technology is prevalent for approximately 20 years, and standards like 802.11a/g and 802.16 have embraced OFDM/OFDMA modulation techniques, we have not found any intelligent use of the technology other than simply using it as a medium of transmission at higher data rates.

The fact that the component sinusoids of an OFDM signal can be easily aggregated to form time domain signals as in eq. 1 empowers us to use any part of the spectrum by suitably selecting the spectral coefficients  $x(k)$ .

$$X(n) = \sum_{i=0}^{N-1} x(k) \sin\left(\frac{2\pi kn}{N}\right) - j \sum_{i=0}^{N-1} x(k) \cos\left(\frac{2\pi kn}{N}\right) \quad (1)$$

Here,  $X(n)$  is the value of the signal at time  $n$  which is composed of frequencies denoted by  $2\pi kn/N$ ,  $k$  is the index of frequency over  $N$  spectral components that divides the available bandwidth with equal spacing and  $x(k)$  gives the value of the spectrum at  $k^{th}$  frequency.

This leads to the notion of non-contiguous OFDM (NC-OFDM) which can degenerate to even a single frequency or *tone*. A Fourier transform of such an NC-OFDM signal reveals the spectral energy and can be detected using fairly simple methods.

The simplicity of OFDM and ease of implementation of such a system has led us to innovate the newer protocols and signaling methods described in the this paper.

## 3. SMART ACKNOWLEDGMENTS

In this paper, we focus on speeding *group communication* using *simultaneous transmission and reception*. There are many types of group communications, the most common of which is broadcast or multicast. Conventional infrastructure wireless networks (*e.g.*, a standard WiFi network) usually only use broadcast packets to translate wired broadcasts into wireless packets. The standard 802.11 physical layer doesn't provide a method for determining if a broadcast was delivered; thus such broadcasts are typically transmitted at the lowest modulation rate (in an effort to increase the reliability of reception). Since broadcast messages are exchanged without acknowledgment control frames, there is a limited scope for the source or the access point (AP) to reliably ensure the reception of the message at the host nodes.

In "ad hoc" networks, broadcast messages are used for many purposes. Typical applications include host discovery, network maintenance, route discovery, etc. For example, wireless protocols such as AODV [18] periodically broadcast a routing table to "neighboring nodes" (meaning those that can hear the message). Nodes also periodically transmit "hello" messages to determine if nodes are still reachable. These messages are typically "unicast" messages, because there is no way to safely determine if they've been received.

Reliable broadcast messages, "hello" link maintenance messages and many other communications share a common pattern: a message is sent and one or more nodes should "vote" on the transmitted message. For reliable broadcasts, the vote is an acknowledgment that "I have received and can decode the message". If a node has not received the message, the sender would retransmit it. Link maintenance messages are almost identical, except that if a formerly "adjacent" node does not receive the message, it is removed from the node neighbors table (with no retransmission). Many other protocols, such as voting protocols, can map to a similar query followed by a yes/no decision from other nodes.

Some of these protocols concerning a single network "link" have an analogous extension to a "network" counterpart. For example, there is considerable work on providing reliable network-wide support for broadcast packets in wireless networks, as well as distributed leader election.

### 3.1 SMACK - Reliable Link Layer Broadcasts

For any reliable broadcast mechanism to be reliable, there must be a clearly defined set of nodes in the network; Figure 1(a) shows a single access point and multiple clients. Each client is assigned a unique "membership number". For our implementation we have chosen the OFDM based physical layer for 802.11a/g as the underlying signaling method. Figure 1(b) shows a schematic illustration of the properties of the OFDM waveform that are needed. A given bandwidth, such as the 2.4Ghz band used by 802.11g, is subdivided into a number of *subcarriers* around a center frequency; that center frequency is the "channel" to which an 802.11 radio is set.

In 802.11g, 53 subcarriers remain for data modulation. Normally, a single transmitter modulates all subcarriers to send high bandwidth data. In our protocol, since we only need to transmit a "yes" or "no", we assign subcarriers to individual nodes, as illustrated in Figure 1(b); different clients are assigned subcarrier bins labeled as  $f_{c1}, f_{c2}, \dots, f_{cn}$  where  $n$  depends on the number of users and the number of subcarriers available. The orthogonality of individual subcarriers allows us to use each of them as separate data carriers for different hosts. Using multicarrier modulation techniques allows the AP to receive ACKs from a greater number of clients in the shortest possible time, dramatically reducing

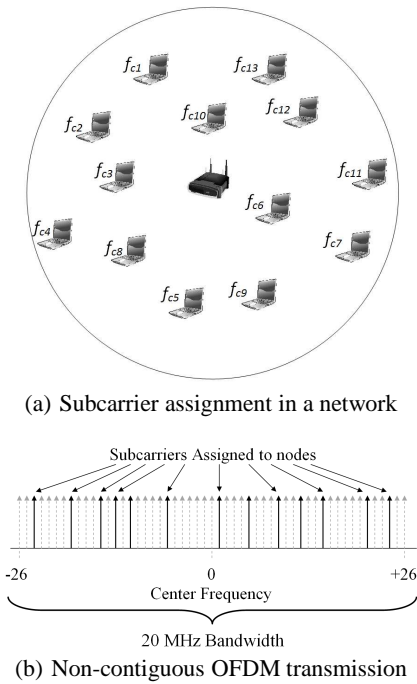

Figure 1: Schematic illustration of ACKs using OFDM

the time to gather reliable acknowledgments for broadcasts. We use the physical layer to combine the responses from the different nodes. Upon receiving a successful broadcast message from the AP the clients use their pre-defined subcarriers to transmit a '1' as an ACK.

To summarize, the protocol has the following steps:

1. When nodes join the network, the AP assigns each node a unique "membership id", which is a small integer.
2. An AP sends the broadcast message using conventional PHY specifications for 802.11a/g.
3. On receiving the broadcast message all clients decode the message (if possible).
4. If a client successfully decodes the message, the client then uses the single orthogonal subcarrier specified by the membership identifier to indicate it has received and decoded the message
5. The AP receives the composite time domain signal of *all* OFDM subcarriers and performs an FFT to obtain the frequency domain representation of the signal. After performing demodulation the individual acknowledgments can be recovered. A one in the  $n^{th}$  bit position can be mapped as an ACK from one of the  $N$  (number of subcarriers) clients.

Due to the conversion between the time domain and frequency domain, relatively tight timing synchronization is needed for the composite additive signal to be decoded at the AP – in other words, all the responding stations must transmit at about the same time; however, that time synchronization is provided by the broadcast message itself as explained in §5.2.

To understand how much more efficient it is to use physical layer signaling, consider the costs of transmitting a message using the

802.11g PHY that is the basis for our extension. A normal message requires a  $20\mu s$  preamble to be transmitted and then, at best assuming the  $54Mbps$  modulation rate, each  $48 \times 6$  bits takes one OFDM symbol time ( $4\mu s$ ) to transmit. Thus, a 64 byte message, which can't actually even contain the Ethernet addresses in a standard 802.11g packet would take at least  $20 + 4 \times 3$  or  $32\mu s$  seconds. After a  $16\mu s$  "SIFS" period for a  $20MHz$  channel [13], clients would normally respond using a similar message format. Thus, a single response to a standard 802.11g packet would take another  $\approx (32 + 16) = 48\mu s$ .

By comparison, using physical layer signaling 53 clients can provide a single bit of information within two OFDM symbol periods, or a total of  $8\mu s$  (as detailed in §5.2), or one-sixth the time for a *single* station to respond using standard messages. This means that using the proposed protocol, the time needed for a single station will be reduced by about an order of magnitude; when the number of potential respondents increases, that time is reduced by two orders of magnitude.

### 3.2 Extending Link Layer Broadcasts

As Figure 1(a) makes clear, we have mainly worried about providing a reliable broadcast for a "single hop" wireless network. We'd still like to have reliable broadcasts in multi-hop wireless networks. Such protocols usually use link layer flooding which often requires re-broadcast and leads to a common phenomenon called a *broadcast storm* [16]. This problem is especially elevated by the lack of ACKs – without an acknowledgment, it's unclear which nodes have received messages. ACK-based broadcast schemes that degenerate the broadcast mechanism into multiple unicast communication increases network overhead and latency. Given a reliable ACK as a basic operation, we can obviously improve on scalable broadcast algorithms [25, 22]. More importantly, we can use the *time of arrival* information available at the physical layer to further improve the performance of reliable network broadcasts. We show how to do this in §10.

## 4. ROBUSTNESS OF SMACK

### 4.1 Against Varying Signal Power

The reliable broadcast acknowledgment scheme described in §3 typically caters to a network of directly reachable nodes. The signal power from these clients may vary widely. Setting a single threshold for all these clients would be difficult if the received signal power of each of the subcarriers at the AP vary in a broad range. Hence, we propose to adjust the transmission power of tone transmitters/clients such that the received power of the subcarriers from different clients at the AP are comparable and within tolerable limits, ensuring that the weaker signal does not get lost due to the high power of the stronger signal. The dynamic transmit power adjustment of the clients can be decided based on existing channel assessment techniques as done in CDMA [1]. The calibration of the transmit power control mechanism based on the channel condition is kept as future work. In this way, we can set a single threshold to detect all the clients in the network, as the received power of the individual subcarriers become similar after adaptive power control. To detect the farthest client, we need to detect its signal. We argue that the weakest client's signal at the AP is not only detectable, but also decodable if a packet is transmitted. Otherwise normal 802.11 communication with that client will not have been possible. In case our proposed protocol fails to detect acknowledgment from the weakest client, the fallback mechanism to retransmit to that particular client will ensure reliable delivery of the broadcast message to the client.

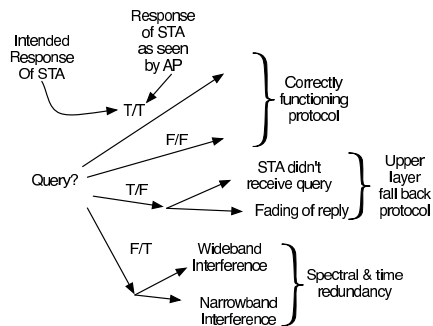

Figure 2: Protocol Fallback Decision Tree

## 4.2 Against Interference

A significant contributor that might cause the protocol to degrade are spurious or burst noise in 2.4 GHz ISM band, e.g., Zigbee, Bluetooth devices, microwave oven and interference from hidden terminals.

In order to address such scenarios we present a fallback mechanism of the protocol which involves upper layer intervention in order to make the protocol robust and reliable in presence of spurious interference. Figure 2 shows the possible states of the protocol and the decision making mechanism at the AP. We start by defining the *cause* and *effect* of the protocol's decision branch. *Cause* refers to the intended responses of the stations/clients and *effect* is defined as the response of the stations/clients as detected by the AP. Both the cause and the effect can have two possible binary states - True or False. Based on all possible combinations of cause and effect we address the error correcting mechanisms or a fallback method.

Branches *True/True* and *False/False* - These two branches exhibit error free functioning of the protocol. If the intended and actual responses match then no error correction is required.

Branch *True/False* - This decision branch can be attributed to instantaneous channel noise between the AP and station. This error can occur in two ways: either the station did not receive the broadcast message or the ACK is attenuated at the AP and fails the threshold test. We refer to the second phenomenon, where the station transmits the tone but the AP does not recognize it, as a *False Negative*. It is possible that a receiver may simply not hear the query and fail to respond. As with any protocol that assumes the absence of response to be meaningful, some higher level method is needed to insure that such a decision is appropriate or that the protocol should be amended to insure that only *positive* responses are acted on.

Branch *False/True* - Wideband or Narrowband noise can cause the threshold test to falsely trigger and we refer this phenomenon as a *False Positive*. As described in section 5.2 the signal detection mechanism operates in a small time window of  $4\mu\text{sec}$  after the SIFS period. So if there exists any unwanted narrowband or broadband signal within the FFT window that can be taken care of in the following way.

Interference can be of two types - either a narrowband or a broadband. We refer to any interference less than  $20\text{MHz}$  bandwidth as *narrowband interference*, which essentially corrupts the intended spectrum partially. Zigbee, which operates in a  $5\text{MHz}$  bandwidth can be one of the potential narrowband interferers. Hidden terminal clients of another AP using our protocol can also be another potential narrowband interferer. To reduce the errors introduced due to narrowband interference, we assign each client multiple subcarriers to transmit ACKs. This mechanism will allow the AP to detect a

false positive by employing a simple *all or nothing* decision metric. If the AP fails to detect energy in all of the subcarriers assigned to a client, it is regarded as a false positive. Assigning multiple random subcarriers  $5\text{MHz}$  apart will ensure robustness against interference from Zigbee nodes. Also, we argue that there exist remote possibilities where a hidden terminal client of another AP in our protocol is assigned the exact same combination of subcarriers as one of the intended clients of our AP and respond in the exact same time slot of our FFT window for detection. Hence, we ignore this problem in this paper.

We refer to any unwanted signal of equal to or more than  $20\text{MHz}$  bandwidth as *wideband interference*, which causes false positives in the detection mechanism at the AP. For a long-lived wideband interference we can eliminate the chances of false detection by performing FFT immediately before and after the protocol window of  $(8\mu\text{sec} + 2\mu\text{sec}) = 10\mu\text{sec}$  as in Figure 4 - if signals are detected prior to or following the intended transmission time, the likely source of those signals would be long-term noise or interference. To detect errors due to wideband interference of duration less than  $10\mu\text{sec}$ , we keep two subcarriers ( $+20$  and  $-20$ ) unassigned to any client. Energy in any of these two subcarriers will detect the presence of a wideband interference. In this scenario, a rebroadcast after carrier sensing can efficiently solve the problem. However, if the wideband interference is very short lived in the order of  $n\text{sec}$  (as in UWB), it will not affect the FFT results as the sampling frequency of our system is  $12.5n\text{sec}$  which is more than the pulse width.

## 5. SYSTEM PARAMETERS

Normal wireless communication is a point-to-multi-point process involving a single transmitter and one or more receivers; our design inverts that assumption. There are some important challenges in implementing such a protocol.

### 5.1 Threshold

The use of thresholds is very common in signal detection and decoding. From the basic operation of carrier sensing in CSMA/CA to maximum likelihood decoding of baseband modulation to even advanced forms of spectrum sensing in cognitive radio environment, all employ some form of threshold testing to extract information from the received signal. In this implementation we utilize Fourier analysis, which is efficiently implemented in hardware using the Fast Fourier Transform (FFT) algorithm. We use threshold tests to identify the presence of spectral components (*i.e.*, is a station transmitting a tone?).

For a fairly simple signaling mechanism as described in §3 we simply need to look at the average signal power to decide on a threshold. Input signal levels are strictly controlled by automatic gain controllers at the receiver front-ends to prevent saturation of the analog to digital converters (ADC). The average received signal strength (RSS) can be measured using eq.2, where  $r(d)$  refers to the received signal samples and  $D$  refers to averaging filter length.

$$R(d) = \sum_{i=0}^{D-1} |r_{d+i}|^2 \quad (2)$$

Figure 3 shows experimental results from hardware where signal energy is averaged over 128 samples. As long as the envelope of the composite waveform is kept constant the average signal energy does not change much and is always above the average noise floor. Thus we argue that this average RSS can be used to determine the threshold level and there is no need to change threshold over time as

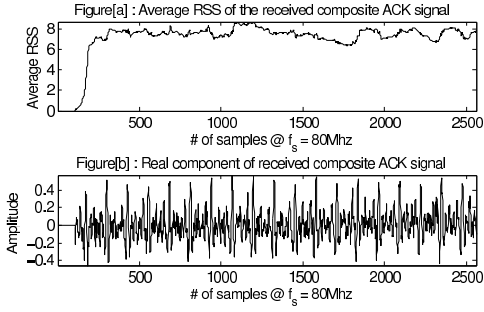

Figure 3: Received signal strength

long as the average signal energy is kept fairly constant by suitable gain controller.

## 5.2 Timing Considerations

The effectiveness of using Fourier transform to extract spectral components requires all the subcarriers to be present with sufficient energy within the FFT window. In this implementation (§6) we have used a 256-point FFT that corresponds to one OFDM symbol ( $3.2\mu s$ ). Therefore, this window of 256 samples should have all the subcarrier information. Evidently, there is an implicit timing constraint imposed on the broadcast node. This is further worsened due to the near-far effect and the different processing power of the clients nodes causing the tones to reach the AP at different times. Therefore the broadcast node has to estimate a suitable FFT window to successfully receive the ACKs. This time is calculated from, after the last sample transmitted to air interface to the first sample of a valid FFT window, which is given by eq. 3.

$$T \geq 2 \times T_{propagation} + T_{r_x, latency} + T_{hardware} + T_{t_x, latency} \quad (3)$$

Assuming a typical distance from the AP to the farthest node in an infrastructure based network to be  $\approx 300m$  results in a round trip delay of about  $2\mu s$ , together with receive-transmit path latencies and  $R_x - T_x$  turnaround time for our hardware ( $T_{r_x, latency} + T_{hardware} + T_{t_x, latency}$ ) allows us to decide on the correct FFT window. Given that each OFDM symbol has a duration of  $4\mu s$ , we can define a *flexible FFT window* which compensates for all the latencies and propagation delays as given in eq.3.

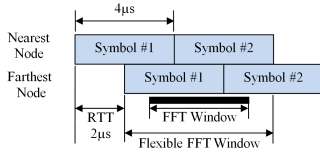

Figure 4: FFT timing requirement

Figure. 4 shows the relative timing diagram and optimum FFT windows. Given a RTT of  $2\mu s$  from the farthest node we start the FFT window anywhere after  $2\mu s$  which gives us enough flexibility against any unforeseen signal delays. The “black bar” marks the optimum FFT window of  $3.2\mu s$  or 256 sample wide.

Unlike single user OFDM transmission, strict receiver timing synchronization is not required since no demodulation is required despite receiving data from multiple clients – we are simply detecting “energy in the channel”. Also, since these are unique single frequency tones, the OFDM subcarriers are transmitted without any PLCP header or any identifiers like pilot tones which saves band-

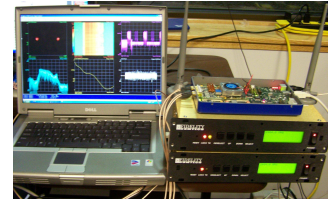

Figure 5: Nallatech boards with radios and antennas

width and makes detection faster at the AP. This makes implementation fairly simple and straightforward, and the technique should be able to be implemented on commodity 802.11 hardware.

## 5.3 Frequency offset and Doppler shift

The composite baseband received signal can be represented by

$$r(n) = \sum_{i=0}^{N-1} A_i e^{j2\pi(f_i + \delta f_o + \delta f_{d_i})nT_s} \quad (4)$$

where  $A_i, f_i, \delta f_o, \delta f_{d_i}$  are respectively the resultant amplitude, subcarrier frequency, frequency offset during down-conversion at the receiver and the Doppler shift for the  $i^{th}$  subcarrier.

Frequency offset correction is extremely important for normal OFDM based packet transmissions. Any residual frequency from the down-conversion stage may cause a significant change in modulation level, which makes it impossible to decode (demodulate) the signal.

This is precisely the reason why we *do not* demodulate the signal – we simply look for power in the subcarrier (*i.e.*, a “tone”). Since we are not worried about modulation levels, any offset in frequency will not affect the FFT results. Thus we argue that since the subcarrier spacing for our implementation is  $312.5KHz$ , carrier frequency offsets, which is typically in tens of  $KHz$  for the radios used in our experiments, will not cause subcarriers to shift frequency bins.

Doppler spread is the maximum frequency shift between the transmitter and the receiver caused by their relative motion or by any scatterer in the environment. Doppler shift is given by eq. 5.

$$f_m = \frac{vf_c}{c} \quad (5)$$

where  $f_m$  is the maximum frequency shift of the signal transmitted at the carrier frequency of  $f_c$ , with a relative velocity of  $v$  between the transmitter and the receiver;  $c$  being the velocity of light. Using eq.5, for a object moving at  $5km/hr$  which is a typical human walking speed we have a maximum Doppler shift of approximately  $11Hz$ . Therefore the Doppler shift is not sufficient to cause spectral leakage onto adjoining subcarriers. Unless the nodes are highly mobile it is very unlikely that the sinusoid envelope will vary to such an extent to cause the threshold test to fail. Neither will it cause the subcarrier to shift frequency bin leading to false detections.

## 6. IMPLEMENTING SMACK USING SDR

To demonstrate simultaneous reception for reliable acknowledgments we implemented a prototype using a SDR platform. The SDR involves an OFDM transceiver on a Virtex-IV FPGA along with a custom front-end radio as shown in Figure 5. The design and implementation has been detailed in [11, 9], which deals with all the signal processing algorithms that have been synthesized into

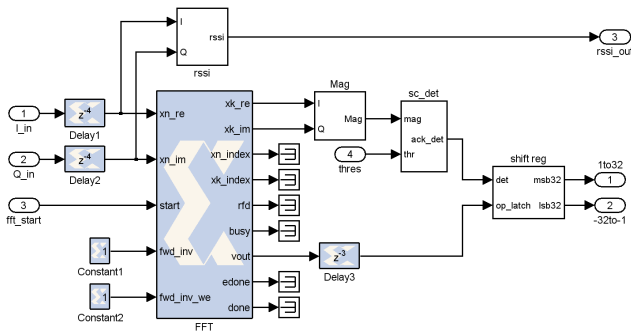

Figure 6: Design for the detecting ACK at AP

fixed point hardware designs. The platform is capable of transmitting and receiving generic 802.11g as given in physical layer specification [13]. The OFDM transceiver components consist of a custom radio front-end responsible for up/down conversion to/from the 2.4GHz ISM band and a Xilinx ExtremeDSP development kit IV manufactured by Nallatech. The ExtremeDSP board includes either a Virtex IV or a Virtex II FPGA equipped with a PCI/USB interface and two sets of A/D and D/A converters. Gain control is also a part of the radio that can be controlled by software on the host computer.

Transceiver latency plays an important role in our implementation. It is required to determine the turnaround time for the receiver at the broadcast node. Usually for any practical transceiver, the minimum time that is required for the MAC/PHY to receive the last symbol of a frame at the air interface process the frame and respond with the first symbol on the air interface of the response frame is of great interest. This includes receiver side PHY layer processing delay + MAC processing delay + Transmitter side processing delay + PCI transfer delay for both Rx and Tx + Front-end radio hardware delay. If we disregard the MAC processing delay and the PCI transfer delay then we can summarize the following:

1. Receiver side:  
Difference between the last symbol received at the air interface to last bit transferred to host =  $14.83\mu\text{sec}$ .
2. Transmitter side:  
Difference between the FIFO read signal to the first analog sample out from the DAC =  $11.68\mu\text{sec}$ .
3. Key note: The FFT/IFFT module consumes the bulk of the latency =  $7.4\mu\text{sec}$ .  $\times 2$  (for Tx and Rx) =  $14.8\mu\text{sec}$ .

It is observed that most clock cycles are consumed by the FFT/IFFT unit and other than that the latency is attributed largely to various buffering elements required for proper functioning of the pipeline. In order to further reduce latency we need to use better pipelined cores with faster cycle times. This is purely a limitation of our prototyping hardware, and not of the method – any commercial WiFi chipset is already capable of the processing needed to implement our technique.

The receiver side of the broadcast node comprises of an FFT engine coupled with the energy detection blocks as shown in Figure 6. This design can form a part of the standard receiver chain [9] and the mode of operation (depending on if the node is operating as a client of AP) can be easily selected using software controlled registers.

As explained in §5.2, triggering the FFT is a key design challenge. Given our hardware design and its inherent latencies, we

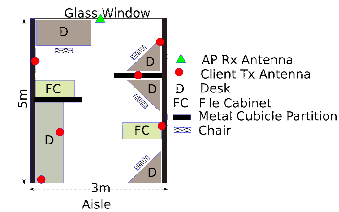

Figure 7: Floor-map of experimental setup

find that the total time required for an ACK to reach the AP is  $(T_{r,x, latency} + T_{t,x, latency}) = 26.51\mu\text{s}$ . Since ACK transmission control logic is done in hardware, no MAC processing delay or PCI/USB data transfer delays are introduced. In order to accommodate any propagation delays and other eventualities we further add a cushion of  $2.49\mu\text{s}$  to the above latency. Thus we trigger the FFT exactly  $29\mu\text{s}$  after the last sample of the broadcast packet transmitted to air interface. This time difference ensures that all the ACK tones from client nodes are available with sufficient energy at the AP to be able to use a simple threshold test to detect them.

The transceiver is operated in the 2.4GHz ISM band with a  $20\text{MHz}$  bandwidth in order to co-exist with other 802.11a/g transmissions. The  $20\text{MHz}$  spectrum is split into 64 subcarriers including the 0<sup>th</sup> subcarrier (d.c.). The 0<sup>th</sup> subcarrier is never used as it will introduce unwanted DC offset at the receiver which has to be removed using suitable algorithms. The output of the energy detector is typically a bit mask of 63 (except the dc subcarrier) subcarriers. This 63 bit mask is read by the MAC layer routine using two software addressable registers. The bit mask for  $-ve$  subcarriers are numbered MSB = -32 to LSB = -1 while the  $+ve$  subcarriers are numbered MSB = 1 to LSB = 33 (which happens to be always zero as we are using 32 subcarriers). For example, if subcarriers [-26, -16, -6, +6, +11, +16] are being used to transmit ACKs then the bit mask for the  $-ve$  frequencies is given by  $0x2008020$  and that of the  $+ve$  frequency is  $0x4210000$ . The presence of a '1' in the bit mask indicates that subcarrier index is used to transmit the ACK. Thus a reliable and fairly simple detection of acknowledgment has been accomplished using a software defined radio.

## 7. EXPERIMENTAL SETUP

In this section, we describe our experimental setup and methodology to understand how feasible subcarrier detection mechanism is in reality.

For compatibility with existing 802.11 compliant networks, our clients would have to transmit an acknowledgment within the SIFS period of the broadcast packet to avoid collision with any other transmissions. However, hidden terminals are not immune to this scenario and may cause collision at the client nodes. However, if the receiver receives the packet and transmits the tone, the chances of collision are very low at the AP. Either a client will transmit a tone due to reception of the broadcast packet, or fail to transmit tones due to the loss of the broadcast packet. Other nodes not participating in the broadcast that are outside the transmission range of the AP will back-off after they sense the broadcast signal transmitted by the AP due to normal carrier sense mechanisms. Thus, coexistence with existing 802.11 networks will not be a problem if stations transmit tones within the SIFS period. The 2.4GHz band is also shared by 802.15 Zigbee nodes as well, but they use similar CSMA/CA sensing mechanism before transmission, which will ensure successful coexistence with our network. Any protocol using a carrier sense media access will similarly be compatible.

Our prototype system, as described in §6, cannot transmit the tone within the SIFS period. Hence, setting up experiments in the presence of other 802.11 networks would induce erroneous results in our protocol evaluation. So, we have used  $2.484GHz$  as the carrier frequency for our experiments. Closest to the IEEE 802.11 channel 11 ( $2.462GHz$ ), this band of  $20MHz$  is free from any transmissions generated by WiFi cards, but has very similar propagation properties to those used by the 802.11 network. This channel is also affected by microwave ovens, and other spurious transmissions generated by different electrical devices (all of which occurred during our prototype evaluation).

Figure 7 shows a floor-plan of our indoor setup, with 6 tone transmitters and 1 receiver/detector. The distances between the transmitters and the receiver in our testbed can be extended, and experiments with longer distances and more number of nodes remain as future work.

## 8. RESULTS

To maximally utilize 7 available radios, we decided to show the performance of our protocol in two steps. The first set of experiments demonstrate the efficiency of the subcarrier detection mechanism, as described in §8.1. The second set of experiments demonstrate actual transmission of a broadcast packet, followed by tone transmission from two nodes on successful reception of broadcast packet, as detailed in §8.2. We used 3 Nallatech Virtex IV PCI boards as 3 client nodes or the tone transmitters. The rest of the 4 boards were Nallatech Virtex II boards equipped with a USB interface. Each of the 6 clients were set in transmit mode, equipped with one radio and a transmitter antenna, continuously transmitting tones in a pre-assigned subcarrier. The detector node is setup in receive mode and repeatedly triggers the detection mechanism to realize the performance of the energy detection scheme. Three of the client nodes were in *line-of-sight* (LOS) of the detector antenna, and the rest were purposefully positioned in *non-line-of-sight* nLOS to introduce sufficient signal distortion. The maximum distance between the transmitter and the receiver antenna was approximately  $5m$ . Antennas were placed at a height of approximately  $2m$  from ground level. All the results shown in Figure 9, 10, 11 and 12 are averaged over five individual experiments at different times of the day, each experiment was performed 10,000 times to detect the tones. This is done to show the robustness of the detection mechanism in presence of ambient noise.

It is to be noted that since we are performing signal processing at baseband using digitized samples, units of various parameters are not important because they are represented using fixed-point precision once converted from the analog domain. For baseband processing, absolute values as quantized by the ADC are important and not the true measured values in units of current or voltage. The actual values in units of current or voltage will depend on the number representation in the design and the dynamic range of the ADCs and other electrical components prior to the ADC. Therefore, without loss of generality and integrity, the units of all our variables are to be interpreted as absolute values.

### 8.1 Efficiency of Tone Detection

In this section, we determine the performance of our protocol, which is based on tone detection in different subcarriers. Initially, we aim to show the variation of signal in both time and frequency domain and how the variation affects the selection of threshold. Then, we have chosen three different setups to analyze the effect of spectral leakage around the desired subcarriers. In experiment 1, evenly spaced subcarriers have been assigned to minimize any spectral leakage. In experiment 2, every alternate subcarrier has

been chosen to detect the effect of spectral leakage in the intermediate unassigned subcarriers. Experiment 3 has been designed to assign contiguous subcarriers for transmission, such that spectral leak may affect detection at the two extremities of the set of subcarriers.

#### 8.1.1 Threshold Selection

To demonstrate the variability of the spectrum over time and its effect on detection percentage, we collected spectrum data in the same indoor setup as shown in Figure 7. The receiver gathered  $204.8\mu s$  of signal, which indicates data for 64 successive FFT computations, each of duration  $3.2\mu s$ . In this way, we collected the composite signal at three different times of the day, resulting in  $(64 \times 3) = 192$  FFT computations. Figure 8 shows the variation of spectrum energy in both frequency and time. There are three regions of signal in time ([1-64], [65-128] and [129-192]), all plotted sequentially. Since coherence time of the channel is more than 64 FFT computations, we do not notice any major change in signal power within a single region. However, individual subcarriers undergo fading at different times of the day, as we move from the region of [1-64] FFT computations to the region of [65-128] computations. Figure 8 also shows that there is a considerable amount of variation from  $-47.93dBm$  to  $-57.26dBm$ , in signal power among different subcarriers at the same FFT computation time. However, these variations are not enough to create a problem in selecting a single threshold,  $-65dBm$  as shown in the figure. Although individual subcarriers undergo attenuation over time the average signal energy envelope remains almost constant. This helps us in maintaining a steady threshold for tone detection.

#### 8.1.2 Experiment #1 - Evenly Spaced Subcarriers

In order to benchmark our system performance we used an Agilent 89600S Vector Signal Analyzer (VSA) to compute the spectral components while we present our computation using the FPGA based FFT engine. For this experiment we have chosen subcarriers  $[-26, -16, -6, +6, +11, +16]$  which are widely spaced not to interfere with each other. Figure 9(a) and 9(b) shows the similarity in the FFT computations by the VSA and our hardware. However it is to be noted that although the measurements are spaced in time and have different subcarrier amplitudes, they provide the same spectral components which have been seen to be consistent over prolonged duration of time. Figure 9(c) shows high detection percentage at lower thresholds, while the percentage of detection of heavily attenuated subcarrier +11 reduces only 2% at the maximum threshold. We notice that the threshold can be easily chosen from a broad range of 6 to 10.

#### 8.1.3 Experiment #2 - Closely Spaced Subcarriers

Subcarriers  $[+6, +8, +10, +12, +14, +16]$  have been used to demonstrate the effect of spectral leakage of detection percentage. Again, Figure 10(a) and 10(b) shows identical spectral components. A drop in detection percentage for subcarrier +14 at threshold 8 can be attributed to instantaneous deep fading during the measurement phase. Figure 10(d) shows that even at low thresholds the number of false positives are low. This really shows that energy in other subcarriers which forms the noise floor for the threshold test is very low.

#### 8.1.4 Experiment #3 - Contiguous Subcarriers

Transmitting tones on contiguous subcarriers, for example,  $[+8, +9, +10, +11, +12, +13]$ , is representative of a pathological case. With results in shown in Figure 11(c) and 11(d) we argue that even with contiguous subcarriers there is very limited inter-subcarrier in-

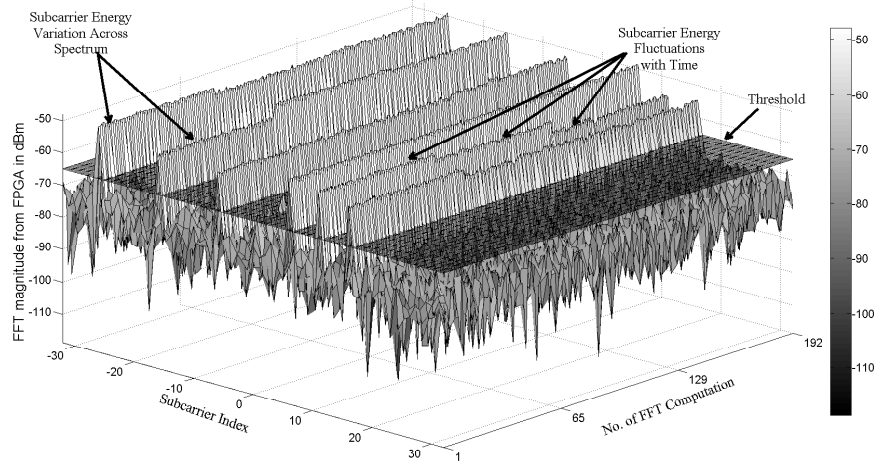

Figure 8: Variation of spectrum over time

terference. The detection percentage and false positives show similar trends to that of experiment #1, which shows that even under the most critical case the spectral components are easily detected by performing simple Fourier transform.

The detection percentage together with the false positives and false negatives in all three experiments show that with our experimental setup and resources, it is not hard to determine an optimal threshold, which is 8 in this case. Threshold test is applied at the output of the FFT engine, using the absolute value of the FFT result on a linear scale. The threshold values show in the Figure 9, 10, 11 are scaled and adjusted numbers to suit the output signals levels of our fixed point FFT engine. The important thing to note is how the detection mechanism performs with changing threshold, rather than the actual number in the threshold axis.

## 8.2 Complete System Performance

To demonstrate the correctness of the detection mechanism and the timing requirements mentioned in §5.2 and §6 we setup a test-bench using three nodes equipped with our SDRs. One of the nodes is setup as the broadcaster, transmitting broadcast packets at regular intervals using BPSK 1/2 rate modulation, and performing an FFT to detect subcarrier energy after  $29\mu s$  as described in §5.2. The other two responder nodes placed at 5m line-of-sight from the broadcaster, and are setup to transmit tones at subcarriers +12 and -12 respectively. The nodes only transmit the tone if they receive a broadcast packet correctly.

Figure 12 shows the overall performance of the complete setup. We notice that with only two subcarriers, the noise floor is very low and percentage of detection is high. The subcarrier -12 has been transmitted at a higher transmit power than subcarrier +12. We notice the effect in our results as well. False Detection is calculated per subcarrier, any false detection in positive frequencies has been considered to be the outliers caused by subcarrier +12, and vice-versa. Threshold 3 appears to be a low threshold for subcarrier -12, with percentage false positive of 2.5%. We notice detection of both the subcarriers -11 and -13 frequently. Since subcarrier +12 has a lower energy, we see that at threshold 12, percentage of detection deteriorates. In this scenario, threshold can be kept anywhere between 5 to 10 for optimum results.

Experimental results in this section not only prove that we can use simple Fourier transform to detect multiple tone transmissions no matter how dense the subcarrier spacing is, but also show that

implementing such mechanism using reconfigurable radio to meet the timing constraints is indeed feasible.

## 9. DISCUSSIONS

In this section, we discuss the robustness of our scheme to low client SNR and SNR variations across clients. In our experiments, the minimum client SNR is measured to be  $15.65dB$  and the maximum as  $27.07dB$ . In networks larger than our testbed, the client SNRs may be lower and span a wider range. Our conjecture is that such scenarios can be addressed as follows: although the maximum and the minimum SNR values will reduce, the power control mechanism, as described in §4.1, should be able to keep the variation within the limits of our current measured SNR range. Despite the fact that the minimum SNR from the weakest client will be less than the minimum shown in our experiments, we argue that if a modulated packet can be decoded from that client, which requires both amplitude and phase detection, our detection mechanism will be able to detect the existence of energy in that subcarrier. However, in low SNR regime, unlike single user OFDM transmission, our multi-user protocol will have different inter-subcarrier interference properties. The effect of such interference in our protocol needs to be evaluated by further experiments.

## 10. BEYOND ACKNOWLEDGMENTS

In this section, we discuss how simultaneous communication mechanism can be utilized in higher layers to improve various protocols.

### 10.1 Reducing Redundant Rebroadcast

We can extend our single hop ACK mechanism further to reduce redundant rebroadcasts in multihop wireless networks by choosing a remote neighbor for the next broadcast in a network-wide broadcast. We exploit the physical layer signaling to estimate the relative distances of the neighbors, by detecting concurrent ACKs. Due to near-far effect, the signal from the “near” node arrives before that of the “far” node, as shown in Figure 4. This can be detected at the physical layer using multiple overlapping FFT’s at the beginning of signal reception. Among the set of nodes that respond we can determine which ones are further away (assuming they take the same amount of overhead time to start the ACK transmission). We can exploit that information and select the farthest node for retransmission of broadcast, thus building a reliable broadcast protocol



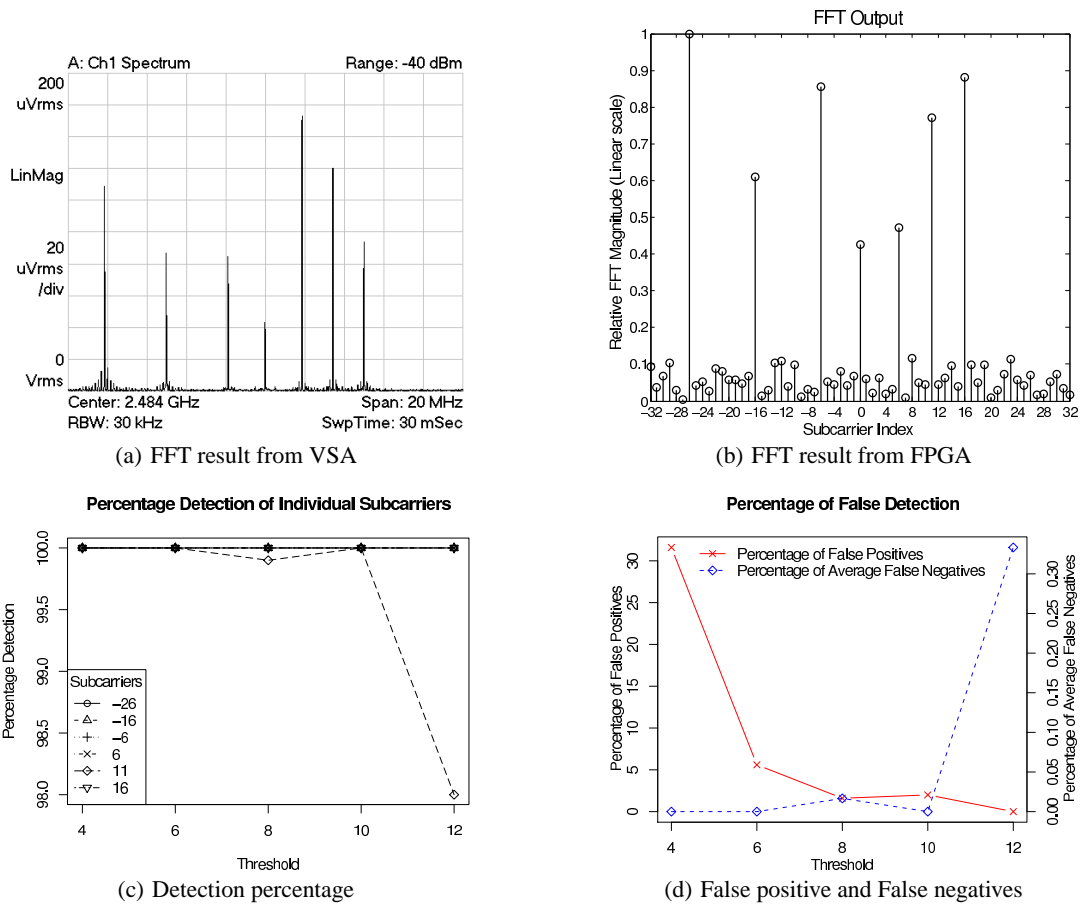

Figure 9: Result of Experiment #1 : Clients transmitting in widely spaced subcarriers - [-26, -16,-6,+6,+11,+16]

in multihop mesh networks with a minimum number of broadcast packets that mitigates broadcast storm.

## 10.2 Parallel Polling

Concurrent communication mechanisms can be utilized in polling nodes whether they have packets to transmit, and based on the polling results, medium access mechanism can be ascertained. The parallel polling mechanism can be used by the AP [21] to query its clients about their queue length. Based on the responses, the AP can assign variable slots to the clients for uninterrupted transmission. This mechanism is faster than any other polling mechanisms, which require transmission of a series of packets by all the participating nodes to know the responses.

## 11. RELATED WORK

This paper presents detection of concurrent transmission as a mechanism to acknowledge broadcast/multicast packets. Mitigating broadcast storm and making the broadcasts reliable are two important issues that are inter-twined and addressed by many researchers in different ways. To reduce redundant broadcasts, the authors in [17] propose several schemes, namely probabilistic, counter-based, distance-based, location-based and cluster-based schemes. However, there is no acknowledgment mechanism to ensure that each of the neighbors have received the message. To ensure reliable broadcast with permanent probabilistic failures, an

asymptotic bound for achievability of broadcast has been deduced in [5].

Acknowledgment is an important phenomenon to report whether a message has been successfully received by the intended receiver. The performance of various response collecting methods, like polling, TDMA and Group Testing, have been compared in [3]. These protocols require transmission of multiple packets transmitted by different nodes, which are distributed temporally. Comparatively, our protocol collects responses simultaneously from multiple nodes within a very short period of time without transmission of any response packets. Demirbas *et al.* [8] proposes *Pollcast* to estimate the number of simultaneous responses of a polling by checking the RSSI; a collision will increase the received signal strength. A variation of similar work has been proposed in *Backcast* [10], where acknowledgment is transmitted without any source address by multiple nodes at the same time. Results show that with fewer nodes, the ACK is decodable and received signal strength approximately indicates the number of concurrent transmissions. Both *Pollcast* and *Backcast* are incapable of detecting the exact neighbor who has transmitted the response. We move a step forward from these mechanisms and not only correctly detect the number of concurrent transmissions, but also detect the exact neighbors which has participated in transmitting the acknowledgment.

The increasing popularity of OFDM in current wireless technologies has convinced us to choose it as the underlying mechanism of communication. It has been embraced by current wire-

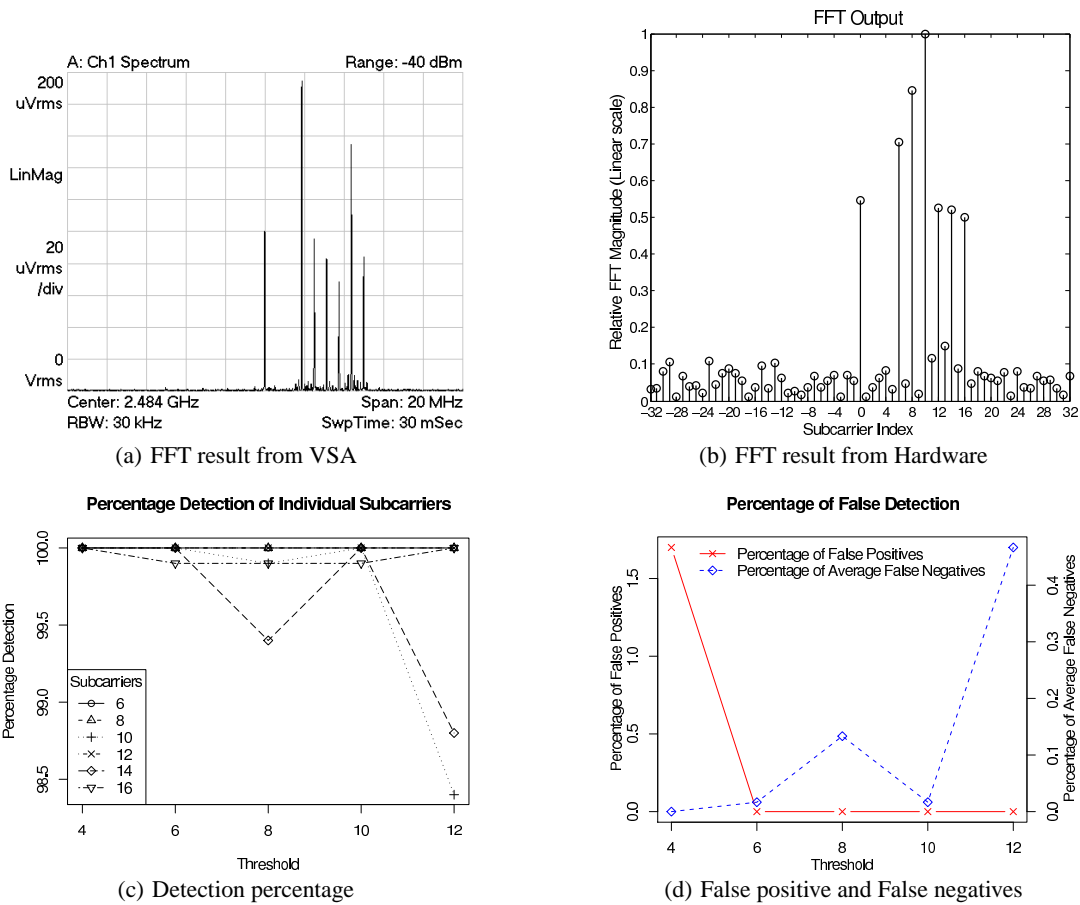

Figure 10: Result of Experiment #2 : Clients transmitting in closely spaced subcarriers - [+6,+8,+10,+12,+14,+16]

less technologies in IEEE 802.11 WLAN [13] and WiMax [14]. It is also one of the physical layer communication system in IEEE 802.22 WRAN [12]. Simultaneous transmission of tones or simply each node transmitting in a single subcarrier, has the same orthogonal property, but requires less complexity at the receiver to detect. OFDM/OFDMA utilizes the bandwidth by transmitting in a set of subcarriers, which requires pilot tones inserted at regular intervals in frequency domain to capture the channel coefficients and aid equalization [7]. To decode a packet transmitted over a set of subcarriers, it is necessary to equalize the received signal with the help of information received from the pilot tones. Our mechanism uses simple energy detection scheme at the receiver without the hassle of equalization and baseband decoding.

OFDMA has also been introduced in cellular network as a simultaneous communication mechanism, where subcarrier assignment [26, 15] considers a set of contiguous subcarriers. Non-contiguous OFDM [19] has mostly been popular in the cognitive radio domain, where a transmitter does not have access to a contiguous set of subcarriers for transmission due to presence of primary users. In this scenario, timing synchronization [2] and decoding the signal is a challenge. Although in our case, the signal generated from multiple nodes is a non-contiguous OFDM signal, our protocol only requires energy detection in each of the subcarriers and hence do not encounter the challenges of non-contiguous OFDM communication.

Simultaneous transmissions can also be detected by the multi-user detection scheme in CDMA. To detect CDMA codes transmitted by the clients, the receiver has to perform correlation for all the  $N$  clients/codes. The post processing of the signal is time consuming if an elimination process is used, or extremely resource consuming if  $N$  parallel correlators are used. To avoid complexity of the problem, researchers [23] use various heuristic methods to obtain a suboptimal solution.

Instances of using simultaneous tone transmissions on OFDM subcarriers for higher layer applications are rare. Energy detection of subcarriers has been utilized by Roman *et al.* [20] in a leader election protocol to eliminate contenders for channel access mechanism. Here, authors use only 8 subcarriers to indicate whether it is contending for the wireless medium. After a few number of contending slots, a winner is decided which gets access to the medium. However we demonstrate the use of the signaling mechanism to address a broader array of network problems. We also address the challenges and scope of implementing such a protocol using reconfigurable hardware, which is the novelty of this work.

Spectrum sensing also forms an integral part in the evolution of cognitive radio based research. Although there are various approaches to find spectrum holes, as given in [4], we still find that the basic operation is a set of threshold tests that ultimately differentiates the *good* signals from the *bad*. Although SNR Wall [24] remains a problem for simple detection mechanism in cognitive domain, our protocol does not suffer from this effect. In cognitive ra-

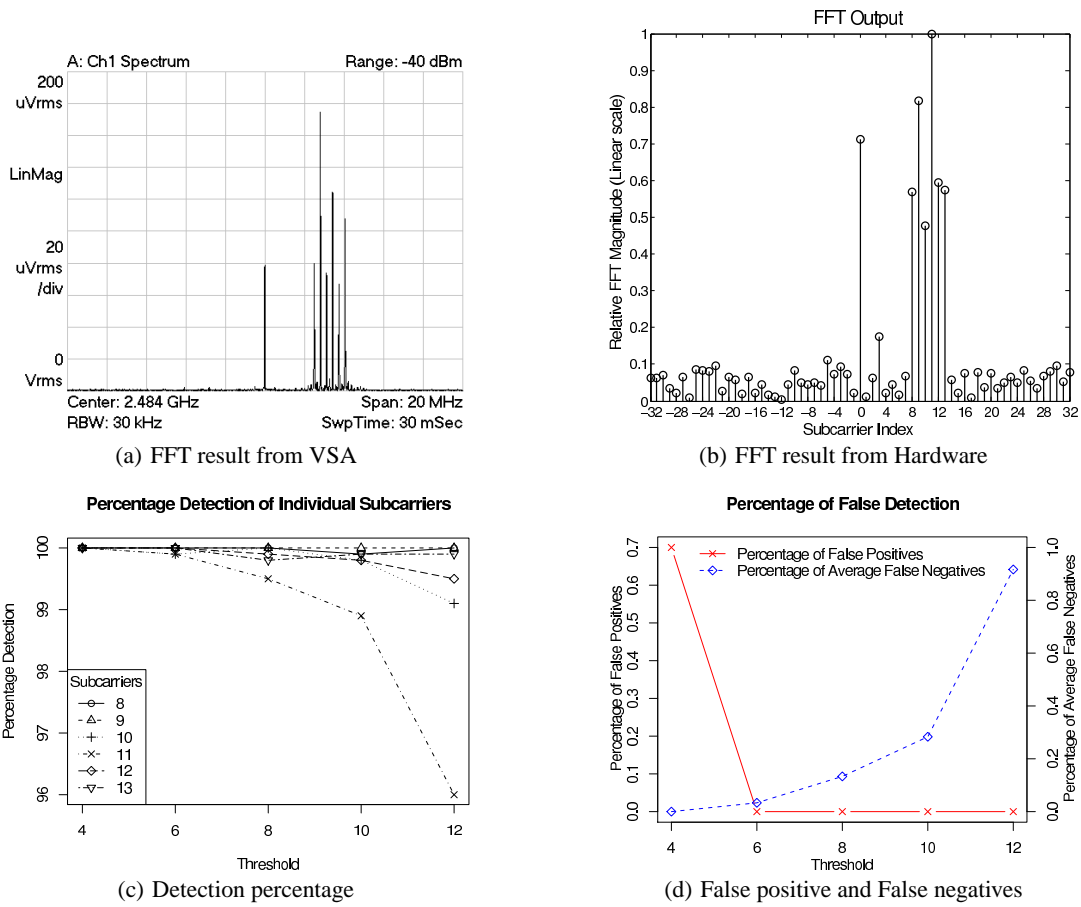

Figure 11: Result of Experiment #3 : Clients transmitting in contiguous subcarriers - [+8,+9,+10,+11,+12,+13]

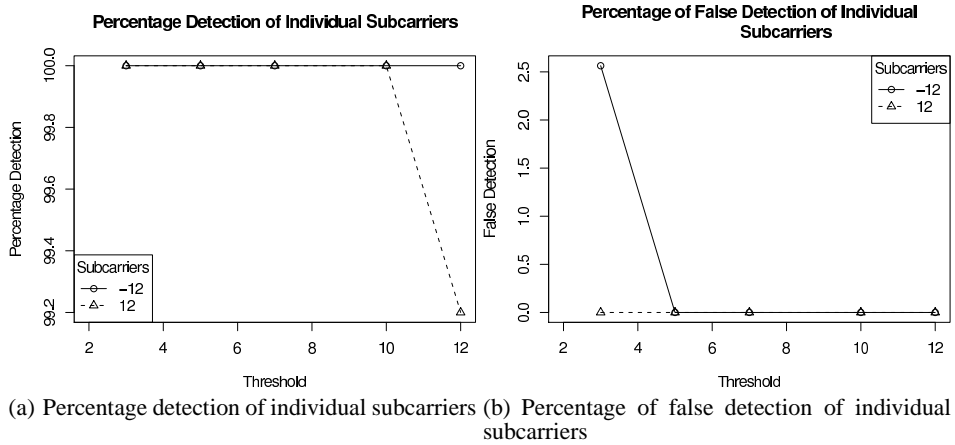

Figure 12: Complete system performance with one broadcaster and two responders

diodes, the secondary user should be able to robustly detect the presence of a primary user in the vicinity even from hidden positions where the primary user's signal goes below the 'SNR Wall' and is difficult to be detected by a simple threshold test. In our protocol, the tones are transmitted by clients of an AP, who are all one-hop neighbors. The signal from those clients are high enough that even packets transmitted by the clients can be decoded at the AP. So, the

signal energy is not as low as we notice in cognitive radio domain and a simple threshold test, as we suggest, can be used to detect the tones.

Prior works in a similar domain powered by simple implementable algorithms has led us to explore beyond the boundaries of preset methods and innovate new protocols in the domain of wireless networks.

## 12. CONCLUSION

We've shown that by using, rather than fighting against, the properties of the wireless physical media, we can develop robust signaling primitives that are both practical and allow innovative algorithms. We used a signaling method based on OFDM that is easy to understand and implement using reconfigurable hardware. We have also shown that if the signaling mechanism is kept simple, not only does it make certain network functions, such as reliable broadcasts faster, but can also use simple detection mechanism to extract the required information. These primitives can also be used to implement higher level group communication and signaling protocols as long as the queries require simple "yes/no" answers. The critical insight is that we can combine the results from multiple clients using simultaneous reception in an efficient manner to aid higher protocols to perform more efficiently.

## 13. REFERENCES

- [1] M. A. Abu-Rgheff. *Introduction to CDMA Wireless Communications*. Academic Press, 1st edition, 2007.
- [2] J. Acharya, H. Viswanathan, and S. Venkatesan. Timing acquisition for non contiguous ofdm based dynamic spectrum access. *New Frontiers in Dynamic Spectrum Access Networks, 2008. DySPAN 2008. 3rd IEEE Symposium on*, pages 1–10, Oct. 2008.
- [3] M. Ammar and G. Rouskas. On the performance of protocols for collecting responses over a multiple-access channel. *INFOCOM '91. Proceedings. Tenth Annual Joint Conference of the IEEE Computer and Communications Societies. Networking in the 90s., IEEE*, pages 1490–1499 vol.3, Apr 1991.
- [4] H. Arslan and T. Yücek. *Spectrum Sensing for Cognitive Radio Applications*, chapter 9, pages 263–289. Springer Netherlands, cognitive radio, software defined radio, and adaptive wireless systems edition, 2007.
- [5] V. Bhandari and N. Vaidya. Reliable broadcast in wireless networks with probabilistic failures. *INFOCOM 2007. 26th IEEE International Conference on Computer Communications. IEEE*, pages 715–723, May 2007.
- [6] R. Chang. Orthogonal frequency division multiplexing. U.S. Patent, Jan 1970.
- [7] S. Coleri, M. Ergen, A. Puri, and A. Bahai. Channel estimation techniques based on pilot arrangement in ofdm systems. In *Broadcasting, IEEE Transactions on*, volume 48, pages 223–229, Sep 2002.
- [8] M. Demirbas, O. Soysal, and M. Hussain. A singlehop collaborative feedback primitive for wireless sensor networks. *INFOCOM 2008. The 27th Conference on Computer Communications. IEEE*, pages 2047–2055, April 2008.
- [9] A. Dutta, J. Fifield, G. Schelle, D. Grunwald, and D. Sicker. An intelligent physical layer for cognitive radio networks. In *WICON '08: Proceedings of the 4th international conference on Wireless internet*, 2008.
- [10] P. Dutta, R. Musaloiu-E., I. Stoica, and A. Terzis. Wireless ACK collisions not considered harmful. In *Proceedings of the Seventh Workshop on Hot Topics in Networks (HotNets-VII)*, October 2008.
- [11] J. Fifield, P. Kasemir, D. Grunwald, and D. Sicker. Experiences with a platform for frequency agile techniques. In *DYSPAN*, 2007.
- [12] IEEE Computer Society : LAN/MAN Standards Committee. *IEEE 802 LAN/MAN Standards Committee 802.22 Working Group on WRANs*.
- [13] IEEE Computer Society : LAN/MAN Standards Committee. *Part 11: Wireless LAN Medium Access Control (MAC) and Physical Layer (PHY) Specifications*.
- [14] IEEE Computer Society : LAN/MAN Standards Committee. *Part 16: Air Interface for Fixed and Mobile Broadband Wireless Access Systems*.
- [15] F. Kojima, H. Harada, and M. Fujise. Adaptive sub-carriers control scheme for ofdm cellular systems. *Vehicular Technology Conference Proceedings, 2000. VTC 2000-Spring Tokyo. 2000 IEEE 51st*, 2:1065–1069 vol.2, 2000.
- [16] S.-Y. Ni, Y.-C. Tseng, Y.-S. Chen, and J.-P. Sheu. The broadcast storm problem in a mobile ad hoc network. In *MobiCom '99: Proceedings of the 5th annual ACM/IEEE international conference on Mobile computing and networking*, pages 151–162, New York, NY, USA, 1999. ACM.
- [17] S.-Y. Ni, Y.-C. Tseng, Y.-S. Chen, and J.-P. Sheu. The broadcast storm problem in a mobile ad hoc network. In *MobiCom '99: Proceedings of the 5th annual ACM/IEEE international conference on Mobile computing and networking*, pages 151–162, New York, NY, USA, 1999. ACM.
- [18] C. E. Perkins and E. M. Royer. Adhoc on-demand distance vector routing. In *Proceedings of the 2nd IEEE Workshop on Mobile Computing Systems and Applications*, pages 90–100, Feb. 1999.
- [19] H. Rahul, N. Kushman, D. Katabi, C. Sodini, and F. Edalat. Learning to Share: Narrowband-Friendly Wideband Networks. In *SIGCOMM '08: Proceedings of the ACM SIGCOMM 2008 conference on Data communication*, pages 147–158, New York, NY, USA, 2008. ACM.
- [20] B. Roman, F. Stajano, I. Wassell, and D. Cottingham. Multi-carrier burst contention (mcbc): Scalable medium access control for wireless networks. *Wireless Communications and Networking Conference, 2008. WCNC 2008. IEEE*, pages 1667–1672, 31 2008-April 3 2008.
- [21] D. Saha, A. Dutta, D. Grunwald, and D. Sicker. Phy aided mac: A new paradigm. *INFOCOM 2009. The 28th Conference on Computer Communications. IEEE*, April 2009.
- [22] S.-T. Sheu, Y. Tsai, and J. Chen. A highly reliable broadcast scheme for ieee 802.11 multi-hop ad hoc networks. volume 1, pages 610–615, 2002.
- [23] P. H. Tan and L. Rasmussen. Multiuser detection in cdma - a comparison of relaxations, exact, and heuristic search methods. *Wireless Communications, IEEE Transactions on*, 3(5):1802–1809, Sept. 2004.
- [24] R. Tandra and A. Sahai. Snr walls for signal detection. *Selected Topics in Signal Processing, IEEE Journal of*, 2(1):4–17, Feb. 2008.
- [25] K. Tang and M. Gerla. Mac reliable broadcast in ad hoc networks. volume 2, pages 1008–1013 vol.2, 2001.
- [26] T. Thanabalasingham, S. Hanly, L. Andrew, and J. Papandriopoulos. Joint allocation of subcarriers and transmit powers in a multiuser ofdm cellular network. *Communications, 2006. ICC '06. IEEE International Conference on*, 1:269–274, June 2006.