

Practical Implementation of Blind Synchronization in NC-OFDM based Cognitive Radio Networks

Aveek Dutta¹, Dola Saha², Dirk Grunwald^{1,2}, Douglas Sicker²

¹Department of Electrical, Computer and Energy Engineering

²Department of Computer Science

University of Colorado

Boulder, CO 80309-0430 USA

{Aveek.Dutta, Dola.Saha, Dirk.Grunwald, Douglas.Sicker}@colorado.edu

ABSTRACT

Spectrum Pooling has lead the cognitive radio research community to a new frontier where it is imperative to examine the architectures of wireless network protocols as well as the underlying hardware. Challenges at the physical layer (PHY) have increased the complexity of the algorithms used in processing a signal with multifarious properties. Synchronization of Non-Contiguous Orthogonal Frequency Division Multiplexing (NC-OFDM) is one such example where a clean slate algorithm and implementation is of utmost need. In this paper, we present a novel algorithm to perform NC-OFDM synchronization in the presence of an incumbent and also provide an outline for a FPGA based implementation of the proposed synchronizer. Extensive simulations under varying signal-to-noise ratio (SNR) and bandwidth reveal significant improvement over existing algorithms employed for NC-OFDM synchronization in cognitive radios.

Categories and Subject Descriptors

C.2.1 [COMPUTER-COMMUNICATION NETWORKS]: Network Architecture and Design—*Wireless communication*; C.3 [SPECIAL-PURPOSE AND APPLICATION-BASED SYSTEMS]: Signal Processing Systems

General Terms

Design, Performance, Verification

Keywords

Cognitive Radio, NC-OFDM Synchronization, Software Defined Radio, FPGA Implementation

1. INTRODUCTION

Bandwidth utilization in wireless communication, not only refers to the range of radio frequencies used in a particular radio-wave transmission but also on the duration of useful communication in the occupied bandwidth. Widespread spectrum measurements [1]

Permission to make digital or hard copies of all or part of this work for personal or classroom use is granted without fee provided that copies are not made or distributed for profit or commercial advantage and that copies bear this notice and the full citation on the first page. To copy otherwise, to republish, to post on servers or to redistribute to lists, requires prior specific permission and/or a fee.

CoRoNet'10, September 20, 2010, Chicago, Illinois, USA.

Copyright 2010 ACM 978-1-4503-0141-1/10/09 ...\$10.00.

have shown the availability of *whitespaces* that can be used by other users as long as they do not interfere with the primary transmission using that part of the spectrum. While shared usage of unused parts of a licensed spectrum provides opportunity of higher bandwidth utilization, it also opens up a whole new world of challenges. Often these unused spectrum are available in *chunks* of frequency bands. The secondary user intending to use these chunks will have to transmit over non-adjacent frequencies while avoiding the frequencies used by the primary user or the incumbent for that band. The term, *Dynamic Spectrum Access (DSA)* has been coined to address the entire family of users that can handle such non-contiguous usage and the devices capable of DSA are termed as *Cognitive Radios*. The Cognitive Radio not only needs to identify unused parts of the spectrum but it also has to provide sustained communication over non-adjacent frequencies.

Co-existence of multiple users using the same carrier frequency has been little known until the evolution of multicarrier communications technologies, like Orthogonal Frequency Division Multiplexing (OFDM) and their subsequent adoption for use in popular wireless protocols. Multicarrier communication offers the advantage of enhanced spectrum utilization by slicing the bandwidth into closely packed non-interfering datacarriers. Once the bandwidth is available, information bits are placed in those data carriers and an inverse Fourier Transform produces one OFDM symbol of duration $N_{fft} \times F_s$ seconds (N_{fft} is width of the Inverse Fourier Transform and F_s is the sampling frequency). At the receiver, a Fourier Transform of this symbol will reveal the information embedded in those data carriers. For the information to be retrieved with no or minimal error, the boundary of an OFDM symbol has to be determined with high accuracy : the effect of mis-estimation is discussed in §3. This accuracy is ensured by the synchronizer in conjunction with other processing units like packet detect and frequency offset correction.

To aid in synchronization, often a known sequence of data bits are transmitted over multiple OFDM symbols at the beginning of every packet and are aptly named the preamble. Symbol timing is extracted using a correlator, whose co-efficients are the exact samples of the time domain representation of the preamble. The uniqueness of the preamble ensure superior correlation at the receiver. Now, when using a shared spectrum, the secondary fails to use the pre-defined preamble, which typically occupies a wider and most importantly contiguous bandwidth than what is currently available. While encoding data over non-contiguous bands is easily achieved, synchronizing at the receiver poses a challenge. A receiver, trying to correlate with the pre-defined preamble will fail since the non-contiguous encoding of the signal has changed the time-domain representation of the preamble. This requires the receiver of a cognitive radio to be able to adapt to the changing en-

vironment. In contrast to the conventional synchronizer, the unit has to be intelligent to be able to identify the data carriers used for the preamble as well as change the co-efficients of the time-domain correlator to search for the correct OFDM symbol boundary. In this research we explore the possibilities of performing an intelligent preamble based correlation for non-contiguous spectrum usage.

Our Contributions: The key contributions of our research are as follows:

- We propose a novel blind (without prior knowledge of the transmitted frequencies) synchronization method for preambles transmitted using NC-OFDM by detecting the spectrum usage and regenerating the preamble for a particular packet.
- In order to show that our algorithm is implementable in realistic hardware, we present a programmable correlator structure that can be synthesized for FPGA.
- Lastly, we analyze the algorithm with a multipath channel with varying SNR that has been shown to yield considerably better results at low SNR and low bandwidth occupancy compared to existing algorithms.

2. RELATED WORK

In this section we discuss prior work which motivated our research and how the proposed algorithm and design compare with similar research in this field. As already addressed, distributed synchronization is critical for NC-OFDM based cognitive radio communication. Blind estimation of OFDM parameters has been studied in detail. Authors in [11, 7], discuss Cyclic Prefix(CP) based autocorrelation algorithms to extract the symbol timing. These methods however work for contiguous OFDM transmission as they rely on estimating the sampling frequency and in turn the FFT/IFFT size. This method is good for coarse symbol timing but does not guarantee a good time-domain correlation for fine timing information. In [2], authors present a theoretical approach to NC-OFDM synchronization. The main drawback of a CP based correlation is that the correlation energy depends greatly on the CP length, number of non-contiguous subchannels used and the number of subcarriers used to encode the signal. In a true cognitive radio these parameters can vary over a wide range, further degrading the quality of the correlation.

Apart from cyclic prefix, embedded cyclostationarity features in the signal have been used to extract symbol timing as discussed in [14]. Unlike conventional OFDM this method requires the modulation of multiple subcarriers with the same information to create the cyclostationarity feature in the signal. This requires more bandwidth than what would be using conventional NC-OFDM. Feng et. al. proposes preamble design using sequences with superior autocorrelation property in [5]. However, it requires high spectral occupancy for successful correlation.

Implementations of NC-OFDM based cognitive radio waveforms has been shown using GnuRadio in [17], which assumes that the receiver has the knowledge of the non-contiguous spectrum used by the secondary transmission, which may not be possible in a true cognitive radio communication. Nolan et. al. in [9], provides an analysis of the preamble based synchronization using NC-OFDM. They have defined bounds on the minimum number of subcarriers required to be able to detect a packet. But this method performs the time-domain correlation with a known preamble which occupies the entire spectrum. This results in degraded correlation when spectrum usage is small.

Platforms like KUAR [10], WARP [8] and SORA [15] are some examples of well-known hardware platforms that support NC-

OFDM transmission. These platforms either use some form of back-end central synchronization method or use a pre-defined set of correlation co-efficients to detect the signal. In contrast to these, our work presents a completely distributed and blind synchronization method suited for a cognitive radio networks.

3. OFDM SYMBOL TIMING

OFDM is a frequency domain modulation technique where the fidelity of the information is highly dependent on the frequency domain properties of the signal, like power spectral density, and phase-magnitude variation across the signal bandwidth. OFDM symbols are generated by inverse Fourier Transform on blocks of data to preserve orthogonality between the subcarriers. Multiple blocks are concatenated in time to form a packet. Often the orthogonality is damaged due to multipath effects of the channel and also by other receiver impairments like incorrect sampling frequency and I/Q offset during downconversion. The block type generation of OFDM calls for a similar decoding method at the receiver to regenerate the frequency domain modulations. Offset in symbol timing introduces phase noise in the subcarriers and affects phase modulations like BPSK and QPSK. The effect of phase noise has been dealt in great detail in previous works [13, 12, 3]. In its simplest form, failure to identify the correct symbol boundary results in phase rotation proportional to the number of samples offset from the correct boundary. Figure 1 shows an example of the effect of timing offset on demodulation. Figure 1(a) is a 16QAM equalized constellation transmitted using 52 subcarriers OFDM, which has no timing offset. The correct timing ensures that there is no phase noise in the I/Q constellation and using the red-dotted lines showing the decoding boundaries the bits can be extracted without errors. In contrast, figure 1(b) shows the equalized constellation, except the signal block is now offset by 8 samples. Significant phase rotation is seen which causes the constellation points to cross the decoding boundaries leading to undesired errors. However, there is an allowable offset that will vary on the amount of the allowable degradation in the constellation, e.g., for BPSK, theoretically, we can allow a rotation of $\pi/2$, although the consequence of such enormous offsets on other processing units are to be considered. Therefore, we argue that for a low to medium SNR an offset of less than 3 samples can be set as a benchmark for error free decoding of a non-contiguous OFDM. This benchmark can only be met by an accurate synchronizer in the time-domain which aims to minimize the root mean squared error for the symbol timing offset over a wide range of occupied bandwidth and SNR.

4. NC-OFDM SYNCHRONIZER

Synchronization of NC-OFDM in the presence of a primary is difficult because the time domain signal changes with change in transmitted frequencies. The time-domain correlation no longer yield satisfactory results for varying spectrum occupancy. To account for this change, we intend to re-establish the correlation properties of a preamble based timing acquisition. This is done in two steps: the spectrum used for a new transmission is detected, followed by regeneration of the preamble using those frequencies and correlation with the incoming signal.

Spectrum detection: Spectrum detection by a secondary receiver is done by threshold based sensing in the frequency domain. During the inter-packet time slot, a cognitive node would perform spectrum sensing. This sensing unit is a Fourier Transform unit operating in continuous pipelined mode, computing the SNR at all subcarriers. If there are two preamble symbols at the beginning of a packet then within two FFT cycles we can determine which

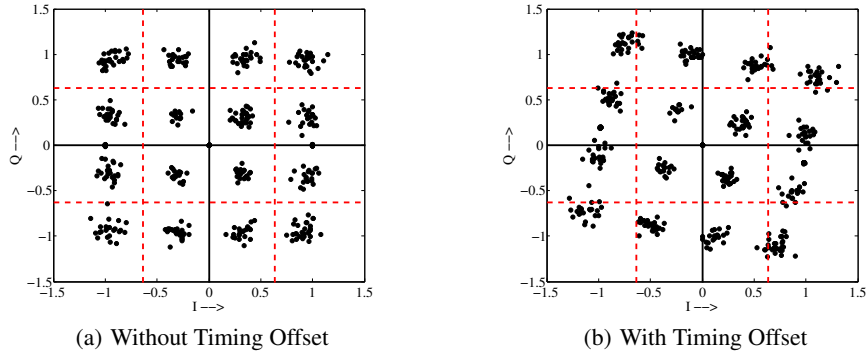

Figure 1: Effect of Symbol Timing Offset: 16QAM Constellation after Equalization at SNR = 15.5 with multipath fading and a timing offset of (-8) samples. The decoding regions are shown by the red colored dotted lines.

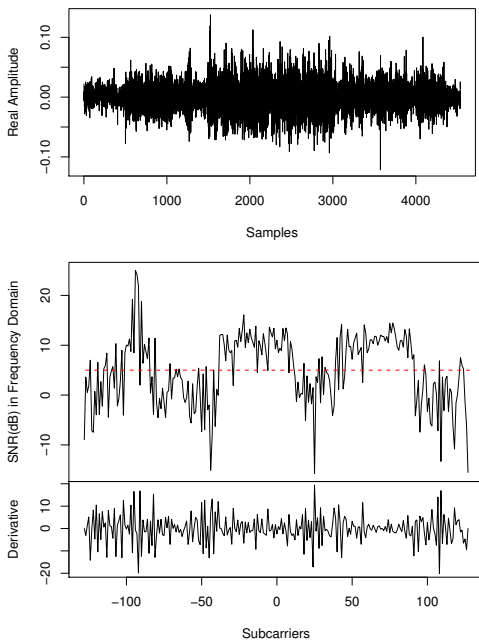

Figure 2: NC-OFDM Waveform - Primary [500 : 4500] and secondary spans [1500 : 3046] samples. Spectral occupancy of Primary is subcarriers $[-95 : -91]$ and for secondary it is $[-38 : 11], [40 : 89]$.

subcarriers are present in the current packet and also the primary frequencies that overlap with the secondary transmission. Therefore, it takes at most two OFDM symbols to determine the correct spectrum. Figure 2 shows a time-domain signal with its frequency domain representation at a received SNR of $10dB$. The spectrum of the wave reveals the subcarrier occupancy of the narrowband primary and the non-contiguous secondary transmission. A threshold of $5dB$ has been used to identify the spectral components which is the minimum SNR required to decode a packet with the lowest data rate (BPSK). We stipulate the minimum number of subcarriers per subchannel to be 10 and if 80% of the subchannel has SNR of at least $5dB$ it indicates the presence of a packet and the correlation can be initiated to extract the timing. Thus using a threshold

test we can derive a binary frequency mask indicating the presence or absence of non-contiguous subcarriers. We often notice outliers (sudden high or low) in the spectral mask, which are removed before further processing. Assuming we have prior knowledge of the subcarriers occupied by the primary, we can *XOR* the primary and secondary masks to extract the secondary subcarriers only. Although edge detection by thresholding on the first order derivative [17] is often used for spectrum detection, it is not suitable for instantaneous detection of spectrum by performing a single FFT on the signal as shown in figure 2.

Correlation: Once the frequency mask is obtained, it is used to regenerate the time-domain preamble locally at the receiver. Using the frequency domain representation of a preamble, we select the indices corresponding to the detected mask while nulling out the other subcarriers. This results in a close approximation of the preamble used by the transmitter. Once the time-domain samples of the preamble is regenerated by an Inverse Fourier Transform, the correlator coefficients are initialized with these samples. After initialization, the correlation energy is computed using a buffered version of the incoming packet to include all time samples from the start of packet.

Update Correlation Coefficients: If the correlation fails to satisfy a pre-defined threshold, then the spectrum sensing unit starts sensing again to feed the new found mask to the correlator. Failure to detect a packet can happen at low SNR regime where the secondary signal is too weak to be detected using the threshold. Under these circumstances we assume that there will be a fallback procedure that relies on back-end message exchange to share the spectral information of the secondary. However, the threshold test is able to determine the correct spectrum over a wide range of SNR which are discussed in §6.

5. FPGA IMPLEMENTATION

In order to show that the synchronizer not only performs better, but is also suitable for hardware implementation, we propose a lightweight correlator structure that augments an existing OFDM based synchronizer. We base our programmable correlator on designs mentioned in prior works [4, 16], which implements synchronizers in hardware for contiguous OFDM. Figure 3 shows the structure of a programmable correlation unit that implements the proposed synchronization algorithm. The key design features of the correlator are as follows:

Acquire Spectrum Information: Spectrum sensing is an in-

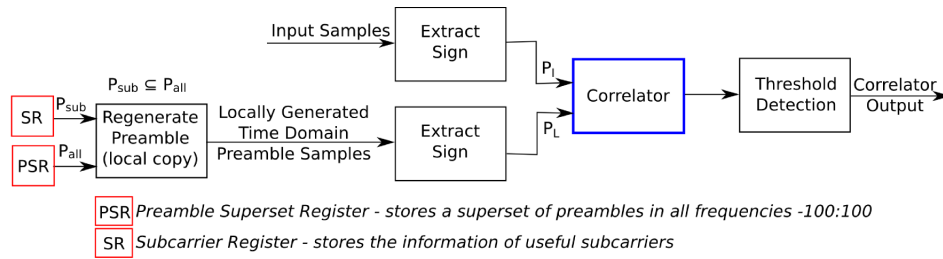

Figure 3: Functional Diagram of Correlator

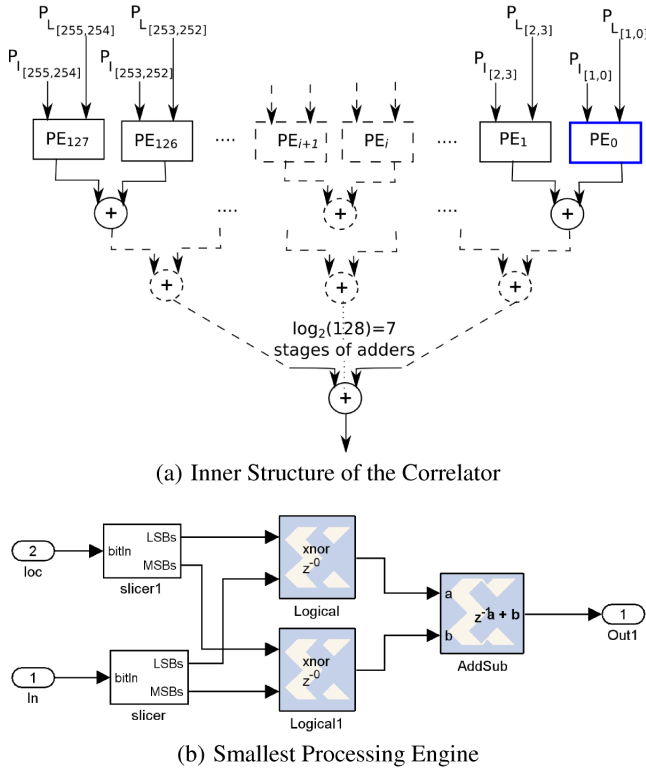

Figure 4: Programmable Correlator Structure

tegral part of cognitive radios. Depending on the design choice, the spectrum sensing unit can be implemented as a part of the radio processing engine or as a separate unit that is part of a cognitive engine. In either case, the correlator should have good coordination with this unit. The spectrum sensing unit provides the correlator and other key baseband processing units, like the equalizer and demodulator, with the information about the subcarriers used in a particular packet. Therefore, a programmable interface is required between the sensing unit and the baseband processing pipeline. Figure 3 shows a set of programmable registers that can be accessed by the spectrum sensing unit to update the subcarrier information of the most recent transmission. The *Subcarrier Register (SR)* holds the subcarrier map to be used for regenerating the preamble in the following step.

Regenerate Preamble: Regenerating the preamble is required to establish the time-domain correlation. Usually for a particular network, the complete frequency domain preamble is pre-defined,

which spans over all the subcarriers. Since Cognitive Radio can operate in multiple networks this preamble can change. In hardware we define a *Preamble Superset Register (PSR)* that holds the complete frequency domain preamble for the current network. Using the subcarrier map from the SR register and the preamble superset from the PSR register, the time-domain preamble is regenerated using inverse Fourier Transform. This preamble is used to perform the correlation with the incoming packet to extract the symbol timing.

Correlator Core: A time-domain correlator employs a running comparison with a local copy of the time-domain samples of the preamble being searched for. The basic operation in a correlator is shift-multiply-accumulate for every fixed-point complex sample entering the correlator. Therefore, depending on the number of samples to be matched, the size of the correlator and the number of gates to implement the logic in FPGA increases. To make the correlator easily implementable, instead of performing wide fixed-point multiplications we use the *sign bit* of the input samples and the locally regenerated preamble. In doing so, the comparison of two samples reduces to a simple XNOR logic operation. Whenever the sign of the input sample matches with that of the local copy, the output is a '1' otherwise '0'. Constructing an adder tree we can accumulate the result of the comparison for every shift operation within a few clock cycles without the need for any additional buffering of the input samples. Figure 4(a) shows the adder tree of the correlator for a 256 sample correlator. For a complex input, similar structure is repeated for the I and the Q paths. Figure 4(b) shows the XNOR processing engine designed using Xilinx System Generator, which performs comparison on two samples. Although the Correlator uses 1 bit instead of the usual 16 bit sample, we still find the performance to be satisfactory under varying SNR.

6. RESULTS AND IMPLEMENTATION

Simulation Results: We have simulated the synchronization algorithm mentioned in §4 using Matlab under varying spectrum allocation and SNR. The parameters used in our simulation are shown in table 1. The channel has been modeled for 802.11a/g using the standard channel model generator (*stdchan*) in Matlab. For this analysis we have used a 5 path delay model and used additive white noise to emulate a realistic scenario. An example of the fading effects of the channel chosen for our experiments is already discussed in §4.

Symbol timing using cyclic prefix (CP) is one of the popular methods of providing synchronization. However, CP provides a coarse estimation of symbol timing [3]. This coarse timing estimate leads to phase noise and erroneous decoding of the signal constellation. In figure 5, the Root Mean Squared Error (RMSE) of CP based timing and our proposed method has been compared. Since CP based timing relies on the length of the cyclic prefix and

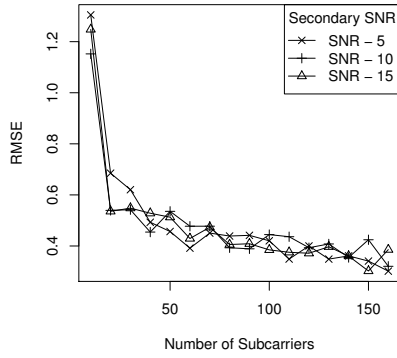

(a) Spectrum Occupancy

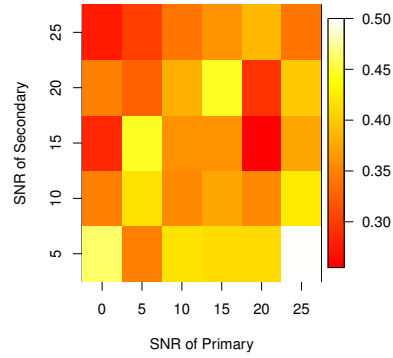

(b) Primary and Secondary SNR

Figure 6: RMSE Performance with Varying Parameters

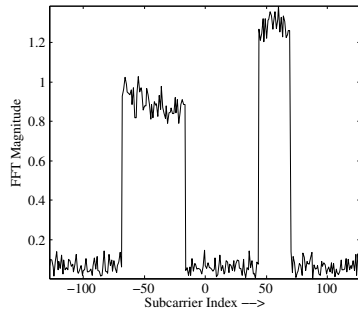

(a) Non-Contiguous Spectrum

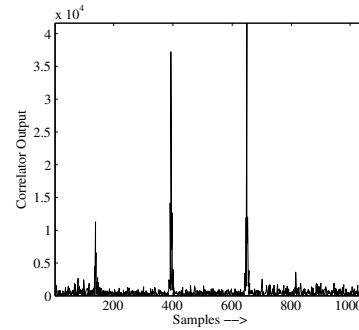

(b) Correlator output

Figure 7: Programmable Correlator Input and Output

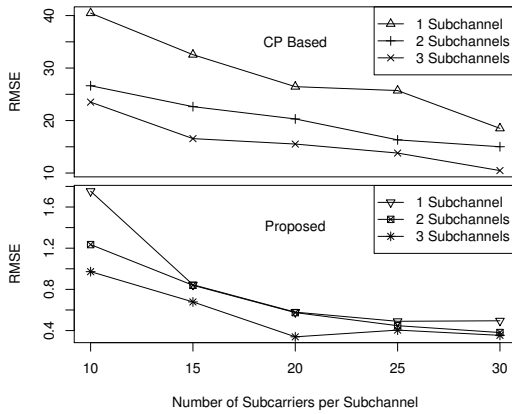

Figure 5: Comparison with Cyclic Prefix Correlation

also on the similarity of the cyclic prefix to the OFDM symbol, the correlation energy is severely degraded for smaller CP length and lower number of non-contiguous subcarriers. Our method shows an improvement of at least 20 times over cyclic prefix correlation. Most importantly the RMSE is below 1 in most of the cases, which is desirable for decoding higher order constellations.

Table 1: NC-OFDM Parameters	
Parameter	Value/Range
FFT Size (N_{fft})	256 samples
Cyclic Prefix size	64 samples
Sampling Frequency (f_s)	80 MHz
Subcarrier spacing (f_s/N_{fft})	312.5KHz
Preamble Superset	802.16 [6]

We study the effects of spectral occupancy while keeping the primary SNR (15dB) and the primary bandwidth (5MHz) constant. Figure 6(a) shows the variation in RMSE with increasing number of subcarriers per subchannel. The RMSE is higher for lower spectral occupancy and decrease slowly with increasing subcarriers. Again, SNR variation does not affect the correlation very much and the RMSE is maintained at considerable low values of 0.4 for 50% spectral occupancy, which is a desirable number for NC-OFDM synchronization.

The performance of the time-domain correlation depends on the presence of a primary user occupying a part of the spectrum. In this analysis we have considered one primary occupying an approximate bandwidth of 5MHz. The secondary spectral occupancy is kept constant at 2 subchannels with 50 contiguous subcarriers covering a bandwidth of 31.2MHz. By varying the SNR for the primary and secondary we analyze the correlator performance. Fig-

ure 6(b) shows the RMSE for symbol timing with varying primary and secondary SNR. RMSE is minimized when the primary SNR is lowest and secondary SNR is highest and lowest when it is otherwise. In spite of a wide variation in the SNRs we find that the RMSE is still maintained at an acceptable range of *less than 0.5*.

Implementation: We have implemented a prototype correlator in FPGA and tested it with a simulated channel also implemented in FPGA due to the unavailability of a wideband front-end. Figure 7 shows the input and output traces of the correlator for a NC-OFDM waveform. As shown in figure 7(a), the input spectrum occupies subcarriers [-68 : -17] and subcarriers [44 : 69] at 10dB SNR. The spectrum detection unit detects this and programs the correlator registers to regenerate the preamble. The *sign* bit and *XNOR* based correlator output is shown in figure 7. Since we have used two preamble symbols to synchronize we get two distinct peaks that are detected using a simple threshold test. These encouraging results motivate us to perform over-the-air experiments using wideband front-ends, which we leave as a future extension of this work.

7. FUTURE WORK

Although the focus of this research has been on fine synchronization of NC-OFDM packets, the ultimate goal remains error-free decoding of a complete packet. In a dense network of cognitive radios, signals from multiple primary and secondary nodes can severely degrade the orthogonality of the subcarriers. As future work, we are interested in exploring the possibilities of synchronizing and decoding NC-OFDM based packets under such realistic scenarios. We plan to test the synchronization algorithm and hardware design using real-time over the air packet transmissions. We also intend to introduce digital filtering techniques to enhance the quality of secondary receptions and finally test the system in whitespaces available in DTV band.

8. CONCLUSION

This paper proposes a novel and practical technique to perform synchronization in NC-OFDM based transmissions. While much work remains to be done, this research shows a new approach towards solving one of the most challenging problems in deploying cognitive radio networks. The proposed method has been shown to outperform significantly when compared to existing solutions. This motivates us to delve deeper into the finer details of the problem. Therefore, we conclude that preamble based correlation in NC-OFDM indeed yields better results at low SNR regime but this also requires a programmable PHY layer hardware that can intelligently control the correlation co-efficients to ensure superior performance.

9. REFERENCES

- [1] Spectrum Occupancy Measurements : <http://www.sharedpectrum.com/measurements/>.
- [2] J. Acharya, H. Viswanathan, and S. Venkatesan. Timing acquisition for non contiguous ofdm based dynamic spectrum access. *New Frontiers in Dynamic Spectrum Access Networks, 2008. DySPAN 2008. 3rd IEEE Symposium on*, pages 1–10, Oct. 2008.
- [3] T. Chiueh and T. P. *Chapter : Synchronization*. John Wiley and Sons (Asia) Pte. Ltd., 2007.
- [4] A. Dutta, J. Fifield, G. Schelle, D. Grunwald, and D. Sicker. An intelligent physical layer for cognitive radio networks. In *WICON 2008: Proceedings of the Fourth International Wireless Internet Conference (WICON 2008)*, New York, NY, USA, 2008. ACM.
- [5] S. Feng, H. Zheng, H. Wang, J. Liu, and P. Zhang. Preamble design for non-contiguous spectrum usage in cognitive radio networks. In *WCNC'09: Proceedings of the 2009 IEEE conference on Wireless Communications & Networking Conference*, pages 705–710, Piscataway, NJ, USA, 2009. IEEE Press.
- [6] IEEE Computer Society : LAN/MAN Standards Committee. *Part 16: Air Interface for Fixed and Mobile Broadband Wireless Access Systems*.
- [7] H. Ishii and G. Wornell. Ofdm blind parameter identification in cognitive radios. In *Personal, Indoor and Mobile Radio Communications, 2005. PIMRC 2005. IEEE 16th International Symposium on*, volume 1, pages 700–705, 11-14 2005.
- [8] P. Murphy, A. Sabharwal, and B. Aazhang. Design of warp: A flexible wireless open-access research platform. In *Proceedings of EUSIPCO*, 2006.
- [9] K. E. Nolan, T. W. Rondeau, P. Sutton, and L. E. Doyle. Tests and trials of software-defined and cognitive radio in ireland. In *SDR Forum Technical Conference and Product Exposition*, 2007.
- [10] R. Rajbanshi, A. M. Wyglinski, and G. J. Minden. An efficient implementation of nc-ofdm transceivers for cognitive radios. In *in Proc. of 1st Conf. on Cognitive Radio Oriented Wireless Networks and Commun., Mykonos*, 2006.
- [11] M. Shi, Y. Bar-Ness, and W. Su. Blind ofdm systems parameters estimation for software defined radio. In *New Frontiers in Dynamic Spectrum Access Networks, 2007. DySPAN 2007. 2nd IEEE International Symposium on*, pages 119–122, 17-20 2007.
- [12] M. Speth, S. Fechtel, G. Fock, and H. Meyr. Optimum receiver design for OFDM-based broadband transmission - II. A case study. In *Communications, IEEE Transactions on*, volume 49, pages 571–578, Apr 2001.
- [13] M. Speth, S. Fechtel, G. Fock, and H. Meyr. Optimum receiver design for wireless broad-band systems using OFDM - I. In *Communications, IEEE Transactions on*, volume 47, pages 1668–1677, Nov 1999.
- [14] P. Sutton, B. Ozgul, K. Nolan, and L. Doyle. Bandwidth-adaptive waveforms for dynamic spectrum access networks. In *New Frontiers in Dynamic Spectrum Access Networks, 2008. DySPAN 2008. 3rd IEEE Symposium on*, pages 1–7, 14-17 2008.
- [15] K. Tan, J. Zhang, J. Fang, H. Liu, Y. Ye, S. Wang, Y. Zhang, H. Wu, W. Wang, and G. M. Voelker. Sora: high performance software radio using general purpose multi-core processors. In *NSDI'09: Proceedings of the 6th USENIX symposium on Networked systems design and implementation*, pages 75–90, Berkeley, CA, USA, 2009. USENIX Association.
- [16] A. Troya, K. Maharatna, M. Krstic, E. Grass, and R. Kraemer. Ofdm synchronizer implementation for an ieeec 802.11(a) compliant modem. In *IASTED International Conference on Wireless and Optical Communication, 2002*, pages 152–157. IASTED, 2002.
- [17] L. Yang, W. Hou, L. Cao, B. Y. Zhao, and H. Zheng. Supporting demanding wireless applications with frequency-agile radios. In *Proc. of ACM/USENIX NSDI*, San Jose, CA, April 2010.