

Codeword Optimization for Uplink CDMA Dispersive Channels*

Dimitrie C. Popescu
Department of Electrical Engineering
University of Texas at San Antonio
6900 North Loop 1604 West
San Antonio, TX 78249-0669
dpopescu@utsa.edu

Christopher Rose
WINLAB
Rutgers University
73 Brett Road
Piscataway, NJ 08854-8060
crose@winlab.rutgers.edu

July 22, 2003

Abstract

We present application of greedy interference avoidance methods to codeword optimization in the uplink of a CDMA system in which the channel between a given user and the base station receiver is assumed known and stable for the duration of the transmission. Repeated application of greedy interference avoidance monotonically increases sum capacity and yields an optimal codeword ensemble which satisfies a simultaneous water filling distribution. However, algorithms for codeword optimization based on the greedy interference avoidance procedure are in general different from water filling schemes. We illustrate the algorithms with examples and look at properties of optimal codeword ensembles.

Index terms: CDMA, codeword adaptation, distributed interference avoidance, sum capacity optimization.

1 Introduction

Wireless channels are often dispersive and dispersion leads to intersymbol interference (ISI) where the energy of a given symbol spills over into the observation intervals of adjacent symbols at the receiver. While the traditional approach to combat ISI was to use equalization and coding techniques, over the past decade multicarrier modulation has emerged as a viable alternative for high speed data transmission systems [1]. The idea behind multicarrier modulation is not new and its theoretical origins date back almost 40 years [10].

More recent work performed in the area of multicarrier modulation falls under two major areas: 1) optimization of transmitted power, and 2) multiple access techniques and signal design. A framework for using multicarrier modulation in frequency dispersive multiple access channels based on discrete multi-tone (DMT) schemes is presented in [5] where a multiuser bit-loading algorithm is also proposed. The algorithm performs multiuser water filling [2] distribution over the DMT tones and maximizes the sum capacity of the multiaccess channel. The fact that a DMT scheme with appropriately loaded carriers is optimal with respect to maximizing sum capacity

*The material in this paper was presented in part at the 37th Allerton Conference on Communication, Control, and Computing, and the 35th Annual Asilomar Conference on Signals, Systems, and Computers.

subject to a given power constraint has been proven optimal [16]. A general iterative water filling procedure applicable to multiaccess vector channel models has been proposed very recently [28].

In the area of signal design we note the work of Honig et al. [11] where optimum signal sets for dispersive channels are derived in a framework based on channel eigen-decomposition [10]. We also note the work of Kasturia et. al [13] and Lechleider [14] which propose codeword design methods for block transmissions suited for multicarrier modulation systems. More recently, in the context of multiuser detection, methods for transmitter and receiver adaptation [20] have also been used for non-ideal channels, although not for a multicarrier modulation framework in particular. Here we note the work of Rajappan and Honig [19], and that of Concha and Uluks [3]. In this case transmitter/receiver adaptation compensates for the distortion introduced by the channel and avoids multiaccess interference.

Our current work falls under signal design since we consider optimization of uplink codewords for a CDMA system in which the dispersive channels between users and base station are known. In this paper we extend application of greedy interference avoidance methods for codeword optimization to dispersive multiple access channels. Interference avoidance is a class of adaptive modulation techniques by which users in a CDMA system adapt their codewords in response to changing patterns of interference in the environment. Interference avoidance was introduced in the context of “chip-based” DS-CDMA systems [23, 24] and minimum mean square error (MMSE) receivers, and was developed in a more general signal space framework in [17, 21, 22].

Our goal is to derive optimal ensembles of user codewords (signature sequences) that maximize the sum capacity of the multiaccess dispersive channel in the uplink of a CDMA system, through application of greedy interference avoidance methods. We note that this is a different problem than that of deriving optimal user transmit covariance matrices which maximize sum capacity, and which are in general found through application of water filling procedures [28]. Of course, the end result will be codeword covariances which correspond to waterfilling solutions, but this is a byproduct of the distributed procedure as opposed to a design feature.

The paper is organized as follows: in section 2 we present the system model and state the codeword optimization problem for a CDMA system when uplink user channels are explicitly considered. In section 3 we provide a brief review of greedy interference avoidance methods for codeword adaptation and prove that application of greedy interference avoidance monotonically increases sum capacity. This result is useful in extending application of interference avoidance methods to dispersive channels, and is not available in previous literature dealing with greedy interference avoidance and the eigen-algorithm [21, 22], although a similar result can be found in [24] for the MMSE update, which is the procedure behind the MMSE algorithm for interference avoidance. Sections 4 and 5 present our main result which is an application of greedy interference avoidance methods to codeword optimization for single and multiple user cases. Numerical results

obtained from simulations and a discussion of optimal codeword ensemble properties yielded by application of greedy interference avoidance are presented in section 6.

2 Problem Statement

We consider the uplink of a wireless system with L synchronous users communicating with a common base station for which the received signal in a given transmission interval is

$$\mathbf{r} = \sum_{\ell=1}^L \Lambda_{\ell} \mathbf{x}_{\ell} + \mathbf{n}. \quad (1)$$

\mathbf{x}_{ℓ} denotes the signal corresponding to user ℓ , \mathbf{n} is the additive Gaussian noise vector that corrupts the signal at the base station receiver, and Λ_{ℓ} is the matrix that describes the uplink channel for user ℓ . This is a standard vector channel model commonly used in conjunction with multicarrier modulation systems, and its derivation can be found in any standard communications textbook (see for example [9, Sec. 6.12-13]).

This model corresponds to a signal space representation in terms of a finite number of frequencies for which the channel matrix Λ_{ℓ} of a given user ℓ is diagonal and contains the channel gains corresponding to frequencies that span the signal space. We note that the real (double-sided) representation, in which sine and cosine of the same frequency make up two orthogonal signal space dimensions with the same *real* channel gain, implies a vector channel of dimension $2N$, where N is the number of frequencies that span the signal space. Alternatively, the complex (single-sided) representation favored in the multicarrier and OFDM literature, which uses complex exponentials as basis functions, implies a vector channel of dimension N with complex gains corresponding to each of the N frequencies that span the signal space.

We assume that each user sends frames containing multiple symbols using a multicode CDMA approach in which each symbol in the frame is assigned a specific codeword (signature sequence) as described schematically in Figure 1. Thus, the transmitted signal vector for user ℓ is

$$\mathbf{x}_{\ell} = \sum_{m=1}^{M_{\ell}} b_m^{(\ell)} \mathbf{s}_m^{(\ell)} = \mathbf{S}_{\ell} \mathbf{b}_{\ell} \quad \ell = 1, \dots, L \quad (2)$$

where $b_m^{(\ell)}$, $m = 1, \dots, M_{\ell}$, denote the symbols sent by user ℓ and $\mathbf{s}_m^{(\ell)}$ is the codeword (signature sequence) corresponding to symbol m of user ℓ .

If the real representation is used then the transmitted symbols and their corresponding codewords are also real, while in the case of the complex representation transmitted symbols and codewords will be complex. We note that if at least as many symbols as signal space dimensions are transmitted by a given user ℓ , then its transmit covariance matrix $\mathbf{X}_{\ell} = \mathbf{S}_{\ell} \mathbf{S}_{\ell}^{\top}$ may span all available signal space dimensions. We also note that the isomorphism between the field of complex numbers

and the field of 2×2 real and skew-symmetric matrices guarantees complete equivalence between the real and complex representations. For simplicity of the mathematical presentation and with no loss of generality, we choose to work with the real framework corresponding to the double-sided signal representation.

With the multicode CDMA frame transmission the received signal vector is expressed as

$$\mathbf{r} = \sum_{\ell=1}^L \Lambda_{\ell} \mathbf{S}_{\ell} \mathbf{b}_{\ell} + \mathbf{n} \quad (3)$$

and our goal is to derive optimal ensembles of codewords, or signature sequences, $\{\mathbf{s}_m^{(\ell)}\}$, $\ell = 1, \dots, L$, $m = 1, \dots, M_{\ell}$ which maximize the sum capacity of the dispersive multiaccess vector channel in equation (3). We note that this is different from the work of Yu et al. [28] which deals essentially with optimal power allocation. While in [28] Yu et al. seek a set of optimal transmit covariance matrices \mathbf{X}_{ℓ} which maximize sum capacity and present a water filling procedure, our goal is to provide a codeword adaptation algorithm and not a water filling procedure. Nevertheless, since we are looking at the same performance criterion as Yu et al. in [28], namely sum capacity, the structure of the transmit covariance matrices implied by the optimal codeword ensemble $\mathbf{X}_{\ell} = \mathbf{S}_{\ell} \mathbf{S}_{\ell}^{\top}$ will satisfy a similar water filling solution.

As we will use interference avoidance methods to derive these optimal ensembles of codewords, we present a brief introduction to greedy interference avoidance in the next section.

3 Reviewing Greedy Interference Avoidance

Interference avoidance methods allow users in a CDMA system to adapt their codewords (signature sequences) to achieve better performance. The main criterion used in the codeword adaptation process is maximization of the signal-to-interference plus noise-ratio.

Interference avoidance was originally introduced in the context of MMSE receiver filters [23, 24], but we concentrate our attention on greedy interference avoidance which uses matched filter receivers and was introduced in [21, 22] and explored in more detail in [17]. In order to review the greedy interference avoidance procedure we consider the uplink of a synchronous CDMA system in which each user ℓ is assigned a unit norm N -dimensional codeword \mathbf{s}_{ℓ} , to convey its information symbol b_{ℓ} . The received signal vector at the base station receiver is

$$\mathbf{r} = \sum_{\ell=1}^L b_{\ell} \mathbf{s}_{\ell} + \mathbf{n} = \mathbf{S} \mathbf{b} + \mathbf{n} \quad (4)$$

where \mathbf{S} is the $N \times L$ codeword matrix having the user codewords \mathbf{s}_{ℓ} as columns, $\mathbf{b} = [b_1 \dots b_L]^{\top}$ is the vector containing the information symbols sent by users, and \mathbf{n} is the additive noise vector

that corrupts the received signal. The covariance matrix of the received signal is

$$\mathbf{R} = E[\mathbf{r}\mathbf{r}^\top] = \mathbf{S}\mathbf{S}^\top + \mathbf{W} \quad (5)$$

Assuming simple matched filters at the receiver for all users, the signal-to-interference plus noise-ratio (SINR) for user ℓ is

$$\gamma_\ell = \frac{1}{\mathbf{s}_\ell^\top \mathbf{R}_\ell \mathbf{s}_\ell} \quad (6)$$

with $\mathbf{R}_\ell = \mathbf{R} - \mathbf{s}_\ell \mathbf{s}_\ell^\top$ being the covariance matrix of the interference-plus-noise seen by user ℓ .

In this framework, greedy interference avoidance is defined by replacement of user ℓ codeword \mathbf{s}_ℓ with the minimum eigenvector of \mathbf{R}_ℓ . This procedure is referred to as *greedy interference avoidance* since by replacing its current codeword with the minimum eigenvector of the interference-plus-noise correlation matrix, user ℓ avoids interference by placing its transmitted energy in that region of the signal space with minimum interference-plus-noise energy and greedily maximizes SINR without looking at the potentially negative effects this action may have on other users in the system.

Although this section is review, we also establish an important property of greedy interference avoidance, namely that it monotonically increases sum capacity defined in this context as [21, 22]

$$C_s = \frac{1}{2} \log(\det \mathbf{R}) - \frac{1}{2} \log(\det \mathbf{W}) \quad (7)$$

We note that a similar result was proven in [24] about the MMSE update, which is the procedure behind the MMSE algorithm for interference avoidance. This property, which is useful in extending application of interference avoidance methods to dispersive channels, is absent from previous literature dealing with greedy interference avoidance and the eigen-algorithm [21, 22]. We also note that extension of the proof in [24] to the greedy interference avoidance procedure based on the minimum eigenvector is not straightforward.

The following lemma, which uses results from majorization theory [15], is useful in proving this result. Majorization theory has been applied in relatively recent work in wireless systems to sum capacity problems [25–27] as well as to signal design and power control for CDMA systems [7]. We mention that the proof in [24] is based on stochastic ordering which is a particular case of the more general majorization relation. The majorization relation between two N -dimensional vectors $\mathbf{a} = [a_1, \dots, a_N]^\top$ with elements $a_1 \geq \dots \geq a_N$, and $\mathbf{b} = [b_1, \dots, b_N]^\top$ with elements $b_1 \geq \dots \geq b_N$ is denoted as $\mathbf{a} \prec \mathbf{b}$ (\mathbf{a} is majorized by \mathbf{b}), and is formally defined by the following sequence of inequalities

$$\sum_{i=1}^n a_i \leq \sum_{i=1}^n b_i, \quad \text{for } n = 1, \dots, N-1 \quad \text{and} \quad \sum_{i=1}^N a_i = \sum_{i=1}^N b_i \quad (8)$$

Lemma 1 : Consider the matrix $\mathbf{V} = \mathbf{Q} + \mathbf{x}\mathbf{x}^\top$ (with $\|\mathbf{x}\| = 1$) for which we apply greedy interference avoidance, i.e. \mathbf{x} is replaced by the minimum eigenvector of matrix \mathbf{Q} . Then, the eigenvalues of \mathbf{V} after the replacement are majorized by the eigenvalues of \mathbf{V} before the replacement.

Proof: Full proof of this result can be found in [17]. ■

Now suppose user k applies greedy interference avoidance and replaces its current codeword \mathbf{s}_k with the minimum eigenvector of the corresponding autocorrelation matrix of the interference-plus-noise \mathbf{R}_k . Since $\mathbf{R}_k = \mathbf{R} - \mathbf{s}_k\mathbf{s}_k^\top$ we can rewrite the sum capacity in equation (7) as

$$C_s = \frac{1}{2} \log[\det(\mathbf{R}_k + \mathbf{s}_k\mathbf{s}_k^\top)] - \frac{1}{2} \log(\det \mathbf{W}) = \frac{1}{2} \sum_{j=1}^N \log \mu_j - \frac{1}{2} \sum_{j=1}^N \log \sigma_j \quad (9)$$

where μ_j are the eigenvalues of \mathbf{R} and σ_j are the eigenvalues of \mathbf{W} which are constant during the replacement of user k codeword. According to Lemma 1, the eigenvalues $\boldsymbol{\mu}'$ of matrix $\mathbf{R}_k + \mathbf{s}_k\mathbf{s}_k^\top$ after the replacement are majorized by the eigenvalues $\boldsymbol{\mu}$ before the replacement: $\boldsymbol{\mu}' \prec \boldsymbol{\mu}$. Using majorization theory we note that for any Schur concave function $g(\cdot)$ this majorization relation implies that $g(\boldsymbol{\mu}') \geq g(\boldsymbol{\mu})$. Function $g(\boldsymbol{\mu}) = \sum_{j=1}^N \log \mu_j$ is Schur concave, and because the second term in equation (9) is constant before and after the replacement of codeword \mathbf{s}_k , the sum capacity of the channel is monotonically increased by application of the greedy interference avoidance procedure.

Sequential application by all users of this greedy SINR maximization procedure defines the eigen-algorithm for interference avoidance [22], formally stated below:

The Eigen-Algorithm

1. Start with a randomly chosen codeword ensemble specified by the codeword matrix \mathbf{S}
2. For each user $\ell = 1 \dots L$
 - replace user ℓ codeword \mathbf{s}_ℓ with the minimum eigenvector of the autocorrelation matrix of the corresponding interference-plus-noise process \mathbf{R}_ℓ
3. Repeat step 2 until a fixed point is reached.

The monotonical increase in sum capacity along with the fact that sum capacity is upper bounded ensure convergence of the eigen-algorithm to a fixed point. Empirical evidence [22] has shown that when starting with randomly chosen codewords this fixed point is the optimal point where sum capacity C_s is maximized. A thorough theoretical analysis of eigen-algorithm fixed point properties can be found in [21] along with a procedure to escape any suboptimal fixed points. Thus, the eigen-algorithm (with escape modifications) always converges to the optimal fixed point

where the resulting codeword ensemble maximizes sum capacity. As a necessary by-product, the aggregate power distribution corresponds to a water filling distribution over those dimensions of the signal space with minimum noise energy.

We emphasize that the water filling solution and the implied maximization of sum capacity are *emergent* properties of greedy interference avoidance, as individual users do not directly attempt to maximize sum capacity through an individual or ensemble water filling scheme, but rather, they greedily maximize the SINR of their own codeword. In fact, individual water filling schemes over the whole signal space are impossible in this framework since each user's transmit covariance matrix $\mathbf{X}_\ell = \mathbf{s}_\ell \mathbf{s}_\ell^\top$ is of rank one and cannot possibly span the N -dimensional signal space.

We also note that the aggregate water filling of the signal space implies that all users achieve uniform maximum SINR [22], and that matched filters are optimal linear receivers in this case [26, 27].

4 The Single User Case

Application of greedy interference avoidance for a single user that communicates over a dispersive channel is a straightforward application of the eigen-algorithm [21, 22] which was presented in the previous section.

In the case of a single user, the received signal in equation (3) becomes

$$\mathbf{r} = \mathbf{\Lambda} \mathbf{S} \mathbf{b} + \mathbf{n} \quad (10)$$

Assuming that $\mathbf{\Lambda}$ is invertible, we can rewrite equation (10) as

$$\tilde{\mathbf{r}} = \mathbf{\Lambda}^{-1} \mathbf{r} = \mathbf{S} \mathbf{b} + \tilde{\mathbf{n}} \quad (11)$$

in which $\tilde{\mathbf{n}} = \mathbf{\Lambda}^{-1} \mathbf{n}$ is a new vector of noise. Equation (11) which describes the equivalent problem is identical to equation (4) and allows straightforward application of the eigen-algorithm to determine the optimal codeword ensemble.

We note that the assumption of channel invertibility is not a restriction in the context of the water filling solution implied by the eigen-algorithm for interference avoidance. This is because water filling solutions dictate that if the noise energy in a dimension is large enough relative other dimensions, then no signal energy can reside in that dimension. Thus, in the context of equation (11), the optimal codeword ensembles will be identical for non-invertible channels and their counterparts made invertible by replacing zero gain elements by sufficiently small but nonzero gains. A careful definition of "sufficiently small" can be stated as a theorem whose proof is a simple consequence of water filling.

Theorem 1 : *Following equation (10), let us consider a non-invertible channel gain matrix Λ^* with $k > 0$ nonzero gains and the invertible matrix Λ*

$$\Lambda^* = \begin{bmatrix} \lambda_1^* & 0 & \cdots & \cdots & \cdots & \cdots & 0 \\ 0 & \ddots & 0 & \cdots & \cdots & \cdots & 0 \\ \vdots & 0 & \lambda_k^* & 0 & \cdots & \cdots & \vdots \\ \vdots & \cdots & 0 & 0 & \ddots & \cdots & \vdots \\ \vdots & \cdots & \cdots & \ddots & \ddots & \ddots & \vdots \\ \vdots & \cdots & \cdots & \cdots & \ddots & \ddots & 0 \\ 0 & \cdots & \cdots & \cdots & \cdots & 0 & 0 \end{bmatrix} \quad \Lambda = \begin{bmatrix} \lambda_1^* & 0 & \cdots & \cdots & \cdots & \cdots & 0 \\ 0 & \ddots & 0 & \cdots & \cdots & \cdots & 0 \\ \vdots & 0 & \lambda_k^* & 0 & \cdots & \cdots & \vdots \\ \vdots & \cdots & 0 & \epsilon & \ddots & \cdots & \vdots \\ \vdots & \cdots & \cdots & \ddots & \ddots & \ddots & \vdots \\ \vdots & \cdots & \cdots & \cdots & \ddots & \ddots & 0 \\ 0 & \cdots & \cdots & \cdots & \cdots & 0 & \epsilon \end{bmatrix}$$

and assume with no loss of generality that $\lambda_i \geq \lambda_{i+1}$. Likewise consider a diagonal noise covariance matrix $\mathbf{W} = E[\mathbf{nn}^\top] = \text{diag}\{\sigma_1^2, \dots, \sigma_N^2\}$. Finally assume unit energy symbols b_i so that the total transmitted signal energy over all dimensions is $E = \text{Trace}[\mathbf{SS}^\top]$. If ϵ is chosen such that

$$\epsilon < \frac{\sigma_j}{\frac{1}{k} \left[E + \sum_{i=1}^k \frac{\sigma_i^2}{\lambda_i} \right]} \quad j = k+1, \dots, N$$

then the set of codeword ensembles which maximize sum capacity for the channel of equation (10) will be identical for Λ^* and Λ .

Proof: The theorem is a simple consequence of water filling and of the fact that interference avoidance provides a codeword ensemble which water fills the signal space. ■

Therefore, in what follows we assume all channels are invertible with no loss of generality.

5 The Multiuser Case

In this section we consider the general case with multiple users for which the received signal is described by equation (3). From user k 's perspective equation (3) can be rewritten as

$$\mathbf{r} = \Lambda_k \mathbf{S}_k \mathbf{b}_k + \sum_{\ell=1, \ell \neq k}^L \Lambda_\ell \mathbf{S}_\ell \mathbf{b}_\ell + \mathbf{n} \quad (12)$$

in which the first term is the desired signal corresponding to user k while the rest represents interference coming from other users and noise. We note that all the Λ_ℓ matrices are assumed invertible, although some of their elements may be of $O(\epsilon)$. Nevertheless, as pointed out in section 4 via Theorem 1, this does not restrict application of greedy interference avoidance since those dimensions corresponding to very small gains will be completely avoided.

Assuming that noise is colored with uncorrelated components, the covariance matrix of the received signal is

$$\mathbf{R} = E[\mathbf{rr}^\top] = \sum_{\ell=1}^L \Lambda_\ell \mathbf{S}_\ell \mathbf{S}_\ell^\top \Lambda_\ell + \mathbf{W} \quad (13)$$

with $\mathbf{W} = E[\mathbf{nn}^\top]$ a diagonal matrix with elements equal to σ_i^2 , $i = 1 \dots N$, representing the noise variances along each signal space dimension.

From the perspective of an individual user, our problem is again that of selecting input codewords for its symbols in the presence of combined noise and interference from other users. Similar to equation (11) we define an equivalent problem for user k , pre-multiplying by the corresponding inverse channel matrix Λ_k^{-1} in equation (12) to obtain

$$\mathbf{r}_k = \mathbf{S}_k \mathbf{b}_k + \Lambda_k^{-1} \left(\sum_{\ell \neq k} \Lambda_\ell \mathbf{S}_\ell \mathbf{b}_\ell + \mathbf{n} \right) \quad (14)$$

The covariance matrix of the received signal corresponding to user k 's inverted channel problem is

$$\mathbf{R}^{(k)} = \mathbf{S}_k \mathbf{S}_k^\top + \Lambda_k^{-1} \left(\sum_{\ell \neq k} \Lambda_\ell \mathbf{S}_\ell \mathbf{S}_\ell^\top \Lambda_\ell + \mathbf{W} \right) \Lambda_k^{-1} \quad (15)$$

and is related to the original received signal covariance matrix by

$$\mathbf{R}^{(k)} = \Lambda_k^{-1} \mathbf{R} \Lambda_k^{-1} \quad (16)$$

The greedy interference avoidance procedure can be applied now for user k 's equivalent problem by replacing codeword m of user k with the minimum eigenvector of the corresponding interference-plus-noise covariance matrix under channel k inversion given by

$$\mathbf{R}_m^{(k)} = \mathbf{R}^{(k)} - \mathbf{s}_m^{(k)} \mathbf{s}_m^{(k)\top} \quad (17)$$

Using Lemma 1, the proof that application of greedy interference avoidance in the multiuser-multicode CDMA context monotonically increases sum capacity is straightforward. Sum capacity is given in this case by an expression identical to that in equation (7), but in which \mathbf{R} has the more complex expression in equation (13). Using the relationship in equation (16) we rewrite sum capacity from user k 's perspective

$$C_s = \frac{1}{2} \log [\det(\Lambda_k \mathbf{R}^{(k)} \Lambda_k)] - \frac{1}{2} \log(\det \mathbf{W}) = \frac{1}{2} \log(\det \mathbf{R}^{(k)}) + \frac{1}{2} \log(\det \Lambda_k^2) - \frac{1}{2} \log(\det \mathbf{W}) \quad (18)$$

and note that the last two terms are constant while user k applies greedy interference avoidance. Furthermore, from equation (17) we have that $\mathbf{R}^{(k)} = \mathbf{R}_m^{(k)} + \mathbf{s}_m^{(k)} \mathbf{s}_m^{(k)\top}$ and following the same line of reasoning as in section 3 we get the desired result.

Numerous algorithms for codeword adaptation can be established based on repeated application of the greedy interference avoidance procedure in the multiuser system, depending on the particular order in which codewords are updated. One example would be the replacement of one

codeword of a given user at one step followed by replacement of a randomly selected codeword of a randomly selected user. Alternatively, one could replace the codeword with the lowest SINR, or the codeword which will maximally increase the sum capacity, over all codewords and users at a given step. While some of these codeword replacement procedures don't look very attractive from an implementation point of view, we mention them to emphasize that codeword replacement based on greedy interference avoidance is in general not a water filling procedure. Nevertheless, the monotonic increase in sum capacity by the greedy interference avoidance procedure along with the fact that sum capacity is upper bounded guarantees convergence of all such algorithms to a fixed point. Furthermore, assuming that each user has at least as many codewords as signal space dimensions¹, then the fixed point is unique and corresponds to a simultaneous water filling solution for users in their equivalent inverted channel problems. This is a particular case of the more general result proved in [28] which states that in general a simultaneous water filling solution corresponds to maximum sum capacity for a multiaccess vector channel. A proof for this particular case, which has been established independently in [28], can be found in [17]. Thus, application of greedy interference avoidance yields an optimal ensemble of codewords which maximizes sum capacity.

The main characteristic of this optimal codeword ensemble is that all codewords of a given user k are minimum eigenvectors of the received signal covariance matrix that corresponds to user k 's inverted channel problem

$$\mathbf{R}^{(k)}\mathbf{S}_k = \mu_k\mathbf{S}_k \quad \forall k = 1, \dots, L \quad (19)$$

The associated eigenvalue μ_k denotes the "watermark" that corresponds to user k 's water filling distribution in its equivalent inverted channel problem. This is also related to the uniform SINR achieved by all symbols of user k as $\gamma_k = 1/(\mu_k - 1)$.

Empirically we have observed that repeated application of greedy interference avoidance with various codeword replacements reaches the optimal fixed point – unless the algorithm is deliberately placed in a suboptimal fixed point at initialization. We need to point out that we do not claim that codewords converge to a particular codeword ensemble, but rather that the procedure converges to a class of codewords which corresponds to maximum sum capacity, the so-called convergence in class [21]. We again emphasize that, in general, these codeword adaptation procedures are different from water filling schemes, even though they converge to a water filling solution.

While we have been unable to prove convergence to the optimal fixed point in general, we mention two particular algorithms for which convergence to the optimal point is provable. The first algorithm updates all codewords of a given user sequentially until a fixed point is reached, and

¹So that, as it was mentioned in section 2, the transmit covariance matrix of each user may water fill the signal space.

then iterates for all users in the system. This is an extension of the eigen-algorithm to the multiuser/multicode scenario, and due to the emergent water filling properties of the eigen-algorithm, represents an instance of the “iterative water filling” procedure in [28]. We formally state this algorithm here:

The Multiuser Eigen-Algorithm for Dispersive Channels

1. Start with a randomly chosen codeword ensemble specified by the user codeword matrices $\mathbf{S}_1, \dots, \mathbf{S}_L$
2. For each user $k = 1 \dots L$
 - (a) Define the equivalent problem for user k as in equation (14)
 - (b) adjust user k 's codewords sequentially: the codeword corresponding to symbol m of user k is replaced by the minimum eigenvector of the autocorrelation matrix of the corresponding interference-plus-noise process in equation (17)
 - (c) Repeat step (b) iteratively for each user until a fixed point is reached for which further modification of codewords will bring no additional improvement.
 - (d) If a suboptimal point is reached use escape methods [21] and repeat steps (b)-(c).
3. Repeat step 2 iteratively for each user until a fixed point is reached for which further modification of codewords will bring no additional improvement.

An alternative algorithm based on greedy interference avoidance, which is not iterative water filling, but for which convergence to a simultaneous water filling solution was proved is:

The Maximum Capacity Increase Algorithm for Interference Avoidance

1. Start with a randomly chosen codeword ensemble specified by the user codeword matrices $\mathbf{S}_1, \dots, \mathbf{S}_L$
2. Define the equivalent problems for all users k as in equation (14)
3. Identify the codeword $\mathbf{s}_m^{(k)}$ whose replacement will maximally increase sum capacity. If no codeword will increase sum capacity, and suboptimal maxima escape methods [21] are ineffective for improvement, then STOP. Otherwise,
 - (a) adjust $\mathbf{s}_m^{(k)}$: replacement by the minimum eigenvector of the autocorrelation matrix of the corresponding interference-plus-noise process in equation (17)
 - (b) Return to step 2

First we note that because at each step the maximum capacity increase algorithm is based on a greedy interference avoidance procedure it cannot decrease sum capacity. Furthermore, the maximum capacity increase algorithm stops only if sum capacity cannot be increased. Thus, the sequence of sum capacity values along any update trajectory must be strictly increasing. A detailed proof of convergence to the optimal point for this algorithm can be found in [17].

So in summary, there are at least two algorithms based on greedy interference avoidance that can be used for codeword optimization with dispersive channels, and which are guaranteed to converge to maximum sum capacity ensembles of codewords. We note that, while the multiuser eigen-algorithm is an instance of iterative water filling [28], the maximum sum capacity increase algorithm is not, although both converge to simultaneous water filling solutions.

6 Additional Properties and Numerical Examples

In this section we provide numerical examples and illustrate properties of optimal codeword ensembles derived using greedy interference avoidance algorithms. We note that these properties have also been discovered independently but concurrently by others; mentioned informally for multiuser DMT systems [6], and in recent work dealing with multicarrier systems [16]. We also note that we look at these properties from a codeword perspective rather than a transmit covariance matrix perspective as it is the case with previous work [5, 6, 16].

One property of the optimal codeword ensemble obtained through greedy interference avoidance, which follows immediately from the results of [21, 22], is that all symbols of any given user k have the same SINR. This property along with the fact that the optimal linear detector for each symbol is a matched filter implies that a uniform receiver structure can be implemented – possibly attractive from a practical standpoint for integration purposes.

Another interesting property is that the optimal received signal covariance matrix \mathbf{R} as well as all inverted channel covariance matrices $\mathbf{R}^{(\ell)}$ are diagonal. This is a consequence of the diagonal noise covariance and channel gain matrices used in our model. In order to see this, we note that the sum capacity expression

$$C = \frac{1}{2} \log \left[\det \left(\sum_{\ell=1}^L \Lambda_{\ell} \mathbf{S}_{\ell} \mathbf{S}_{\ell}^{\top} \Lambda_{\ell} + \mathbf{W} \right) \right] - \frac{1}{2} \log(\det \mathbf{W}) \quad (20)$$

can also be rewritten as

$$C = \frac{1}{2} \log \left[\det \left(\sum_{\ell=1}^L \tilde{\Lambda}_{\ell} \mathbf{S}_{\ell} \mathbf{S}_{\ell}^{\top} \tilde{\Lambda}_{\ell} + \mathbf{I} \right) \right] \quad (21)$$

with

$$\tilde{\Lambda}_{\ell} = \mathbf{W}^{-1/2} \Lambda_{\ell} = \text{diag} \left\{ \frac{\lambda_1^{(\ell)}}{\sigma_1}, \dots, \frac{\lambda_n^{(\ell)}}{\sigma_n}, \dots, \frac{\lambda_N^{(\ell)}}{\sigma_N} \right\} \quad \ell = 1, \dots, L \quad (22)$$

Equation (21) can also be thought of as representing sum capacity for an N -dimensional multiaccess vector channel with L users, in which each user transmits a fraction $p_n^{(\ell)}$ of its total power over scalar channel $n = 1, \dots, N$ with corresponding gain $g_n^{(\ell)} = \lambda_n^{(\ell)} / \sigma_n$ corrupted by additive white Gaussian noise with unit variance. For such a scalar multiaccess channel sum capacity is equal to [4, p. 405]

$$C_n = \frac{1}{2} \log \left(1 + \sum_{\ell=1}^L g_n^{(\ell)2} p_n^{(\ell)} \right) \quad (23)$$

and the sum capacity of the corresponding N -dimensional multiaccess vector channel can be written as

$$C = \frac{1}{2} \sum_{n=1}^N C_n = \frac{1}{2} \log \prod_{n=1}^N \left(1 + \sum_{\ell=1}^L g_n^{(\ell)2} p_n^{(\ell)} \right) \quad (24)$$

We note that the sum capacity value in equation (24) is the information theoretic upper bound on sum capacity of a multiaccess vector channel and that the sum capacity value in equation (21) is equal to that in equation (24) only at the optimal point corresponding to the simultaneous water filling solution.

The fraction of power transmitted by user ℓ over scalar channel n is given by

$$p_n^{(\ell)} = \sum_{m=1}^{M_\ell} s_{mn}^{(\ell)2} \quad (25)$$

and is obtained by summing up the squared component n of all codewords $m = 1, \dots, M_\ell$ of user ℓ . We note that $p_n^{(\ell)}$ is the n^{th} element of the main diagonal of $\mathbf{S}_\ell \mathbf{S}_\ell^\top$. Therefore, the term $g_n^{(\ell)2} p_n^{(\ell)}$ represents the n^{th} diagonal element of $\tilde{\Lambda}_\ell \mathbf{S}_\ell \mathbf{S}_\ell^\top \tilde{\Lambda}_\ell$, and the term $1 + \sum_{\ell=1}^L g_n^{(\ell)2} p_n^{(\ell)}$ is the n^{th} diagonal element of $\sum_{\ell=1}^L \tilde{\Lambda}_\ell \mathbf{S}_\ell \mathbf{S}_\ell^\top \tilde{\Lambda}_\ell + \mathbf{I}$. This implies that the determinant of the matrix that appears in the sum capacity expression in equation (21) is actually equal to the product of its diagonal elements. By Hadamard inequality [12, p. 477] we know that for a positive definite matrix, as is the case with $\sum_{\ell=1}^L \tilde{\Lambda}_\ell \mathbf{S}_\ell \mathbf{S}_\ell^\top \tilde{\Lambda}_\ell + \mathbf{I}$, the determinant is equal to the product of its diagonal elements if and only if the matrix is diagonal. As a consequence, this implies the desired result, namely that the optimal received signal covariance matrix \mathbf{R} , as well as all inverted channel covariance matrices $\mathbf{R}^{(\ell)}$ are diagonal.

The following properties deal with signal space partition among users at the optimal point and potential overlap between subspaces in which users reside. We first note that if codeword matrices of two given users each spans the whole signal space, then these users must have identical channels. In order to see this, we use equations (16) and (19) to write for any pair of distinct users i and j at the optimal point

$$\Lambda_i^{-1} \mathbf{R} \Lambda_i^{-1} \mathbf{S}_i \mathbf{S}_i^\top = \mu_i \mathbf{S}_i \mathbf{S}_i^\top \quad \text{and} \quad \Lambda_j^{-1} \mathbf{R} \Lambda_j^{-1} \mathbf{S}_j \mathbf{S}_j^\top = \mu_j \mathbf{S}_j \mathbf{S}_j^\top \quad (26)$$

If the two distinct users i and j both span the signal space then matrices $\mathbf{S}_i \mathbf{S}_i^\top$ and $\mathbf{S}_j \mathbf{S}_j^\top$ are invertible, and by post-multiplying with their inverses followed by appropriate multiplication by the corresponding channel matrix we get

$$\mathbf{R} = \mu_i \mathbf{\Lambda}_i = \mu_j \mathbf{\Lambda}_j \quad \implies \quad \mathbf{\Lambda}_i = \frac{\mu_j}{\mu_i} \mathbf{\Lambda}_j \quad (27)$$

which shows that user i 's channel matrix is a scaled version of user j 's channel matrix. Or in other words, that users i and j see the same channel. This remark is an indication that the signal space is frequency partitioned at the optimal point. That is, codeword matrices of users with different channels cannot contain all frequency components.

Now, suppose we make the following assumption.

Assumption: *The ratio of channel gain magnitudes for any pair of users $i \neq j$ is different for different dimensions $r \neq s$ corresponding to different frequencies $f_r \neq f_s$.*

$$\frac{|\lambda_r^{(i)}|}{|\lambda_r^{(j)}|} \neq \frac{|\lambda_s^{(i)}|}{|\lambda_s^{(j)}|} \quad \forall i \neq j \in \{1, \dots, L\}, r \neq s, f_r \neq f_s \quad (28)$$

This is a reasonable assumption for some level of precision ε in the representation of channel eigenvalue matrices since a small perturbation $O(\varepsilon)$ will spoil any potential equality.

Under this assumption we note that at the optimal point no two users can reside in subspaces that overlap in more than one frequency. This property has been observed in the context of discrete multitone systems by S. Diggavi [5, 6]. To see this we use again equation (16) to write for any distinct users i and j

$$\mathbf{R} = \mathbf{\Lambda}_i \mathbf{R}^{(i)} \mathbf{\Lambda}_i = \mathbf{\Lambda}_j \mathbf{R}^{(j)} \mathbf{\Lambda}_j \quad (29)$$

and note that the diagonal structure of matrices in equation (29) implies that for any dimension r in which users i and j overlap we have

$$\mu_i |\lambda_r^{(i)}|^2 = \mu_j |\lambda_r^{(j)}|^2 \quad \iff \quad \frac{|\lambda_r^{(i)}|^2}{|\lambda_r^{(j)}|^2} = \frac{\mu_j}{\mu_i} \quad (30)$$

According to equation (28) the ratio of channel gains for users i and j differs for distinct dimensions corresponding to different frequencies. Thus, equation (30) is true for one and only one frequency f_r , which implies that any pair of users with codeword matrices $\mathbf{S}_i \neq \mathbf{S}_j$ can overlap at most in one frequency at the optimal point.

Finally we note that if two users i and j reside in overlapping subspaces, then the overlap occurs in the minimum gain ratio dimension over all dimensions spanned by the user. This property has been noted in recent work on multicarrier modulation [16]. In order to see this we note that the

simultaneous water filling solution implies that for any user i the eigenvalue μ_i in equation (19) is the minimum eigenvalue of $\mathbf{R}^{(i)}$. Thus, for any pair of users i and j we can write

$$\mu_j \leq \frac{|\lambda_s^{(i)}|^2}{|\lambda_s^{(j)}|^2} \mu_i \quad \forall s = 1, \dots, N \quad (31)$$

If users i and j overlap in dimension r then

$$\mu_j = \frac{|\lambda_r^{(i)}|^2}{|\lambda_r^{(j)}|^2} \mu_i \leq \frac{|\lambda_s^{(i)}|^2}{|\lambda_s^{(j)}|^2} \mu_i \quad \text{or} \quad \mu_i = \frac{|\lambda_r^{(j)}|^2}{|\lambda_r^{(i)}|^2} \mu_j \leq \frac{|\lambda_s^{(j)}|^2}{|\lambda_s^{(i)}|^2} \mu_j \quad (32)$$

which indicates that overlap occurs in that dimension r corresponding to a *minimum* gain ratio for user i over user j , as well as *minimum* gain ratio for user j over user i . Note that the minimum gain ratio for a given user is taken only over those dimensions that are actually spanned by that user.

Finally, it is also worth pointing out that the property that in the optimal codeword ensemble two users cannot overlap in more than one frequency generalizes (for a fixed number of users) as the number of frequencies that span the signal space $N \rightarrow \infty$ to distinct frequency bands for different users². Such Frequency Division Multiple Access (FDMA) is well-known to maximize the sum capacity of multiple access channels with ISI [2].

We now present numerical examples to illustrate all the above mentioned properties of codeword ensembles obtained through application of greedy interference avoidance. We start with a simple example of $L = 2$ users in a signal space spanned by $N = 3$ frequencies. The channel gains have been generated randomly from a uniform $[0, 1]$ distribution, and in the real notation used in the paper are given by the diagonal matrices

$$\mathbf{\Lambda}_1 = \text{diag}\{0.9501, 0.9501, 0.2311, 0.2311, 0.6068, 0.6068\}$$

$$\mathbf{\Lambda}_2 = \text{diag}\{0.4860, 0.4860, 0.8913, 0.8913, 0.8913, 0.8913\}$$

Background noise is assumed white with covariance matrix $\mathbf{W} = 0.1\mathbf{I}_6$. Initial user codeword matrices have also been generated randomly, and after interference avoidance is performed we obtain codeword matrices

$$\mathbf{S}_1 = \begin{bmatrix} -0.6839 & -0.9287 & 0.2542 & -0.5889 & -0.5243 & -0.8021 \\ -0.7264 & -0.3391 & 0.9625 & 0.6574 & 0.7282 & 0.3584 \\ 0 & 0 & 0 & 0 & 0 & 0 \\ 0 & 0 & 0 & 0 & 0 & 0 \\ -0.0561 & -0.0298 & 0.0672 & 0.1011 & -0.3900 & 0.2844 \\ -0.0378 & -0.1473 & -0.0661 & -0.4591 & 0.2067 & 0.3837 \end{bmatrix}$$

²As the number of frequencies that span the signal space increases to infinity, overlap is on a set of zero measure, which means essentially that different users do not overlap at all.

$$\mathbf{S}_2 = \begin{bmatrix} 0 & 0 & 0 & 0 & 0 & 0 \\ 0 & 0 & 0 & 0 & 0 & 0 \\ -0.8332 & 0.0987 & -0.1800 & 0.7432 & 0.4777 & -0.3377 \\ -0.3767 & -0.1830 & 0.2566 & 0.5001 & -0.8048 & 0.7013 \\ 0.2332 & 0.9306 & 0.3276 & 0.2180 & 0.3406 & 0.4836 \\ 0.3309 & -0.3014 & 0.8913 & 0.3874 & 0.0896 & -0.4004 \end{bmatrix}$$

Obviously the codeword matrices do not span the whole signal space. More precisely, in this case user 1 spans the subspace determined by frequencies 1 and 3, while user 2 spans the subspace corresponding to frequencies 2 and 3. The water filling distribution that corresponds to each user's inverted channel problem can be observed by looking at the covariance matrices which are

$$\mathbf{R}^{(1)} = \text{diag}\{2.7707, 2.7707, 26.1235, 26.1235, 2.7707, 2.7707\}$$

$$\mathbf{R}^{(2)} = \text{diag}\{10.5906, 10.5906, 1.7568, 1.7568, 1.7568, 1.7568\}$$

One can also see that users overlap in frequency 3 which is a minimum gain ratio for both users.

We provide another example, this time using the complex framework, and with more users and spanning frequencies than before, so that the overlap properties may be better observed. Specifically, this time we consider $L = 3$ users in a signal space spanned by $N = 6$ frequencies. Channel gains are now complex and have been generated randomly with magnitudes from a uniform $[0, 1]$ distribution and phases from a uniform $[0, 2\pi]$ distribution, and are given by

$$\mathbf{\Lambda}_1 = \text{diag}\{ 0.6846 + 0.1147j, -1.2257 - 0.6181j, -1.1892 + 0.9122j \\ -1.0797 - 0.3725j, -1.2828 - 0.5019j, -1.1035 + 0.2680j \}$$

$$\mathbf{\Lambda}_2 = \text{diag}\{ -0.9718 - 0.5980j, 0.6201 - 0.1887j, -0.0201 + 1.2044j \\ -1.1099 + 0.4045j, 0.9421 - 0.9676j, -0.5317 + 0.1375j \}$$

$$\mathbf{\Lambda}_3 = \text{diag}\{ 1.1239 + 0.9118j, -0.1903 - 0.8703j, -0.2968 + 1.2641j \\ 0.8515 + 0.8314j, 0.1989 + 0.5522j, -0.6658 + 0.0941j \}$$

Background noise is also white with covariance matrix $\mathbf{W} = 0.1\mathbf{I}_6$. Initial user codeword matrices have also been generated randomly, and after interference avoidance is performed we get the optimal codeword matrices

$$\mathbf{S}_1 = \begin{bmatrix} 0 & 0 & 0 \\ 0.5577 - 0.2000j & -0.6635 + 0.1138j & 0.6596 - 0.1263j \\ 0.2376 + 0.1994j & -0.1306 + 0.2040j & 0.0585 + 0.2054j \\ 0 & 0 & 0 \\ 0 & 0 & 0 \\ 0.7435 & 0.6986 & 0.7095 \end{bmatrix}$$

$$\begin{bmatrix} 0 & 0 & 0 \\ -0.2676 + 0.4501j & 0.6358 & 0.7429 \\ -0.3773 - 0.3602j & -0.5437 - 0.1581j & 0.2580 - 0.4668j \\ 0 & 0 & 0 \\ 0 & 0 & 0 \\ 0.6736 & -0.4682 - 0.2364j & 0.0793 + 0.3967j \end{bmatrix}$$

$$\mathbf{S}_2 = \begin{bmatrix} 0 & 0 & 0 \\ 0 & 0 & 0 \\ 0 & 0 & 0 \\ 0.7710 & 0.1903 + 0.2344j & -0.1810 - 0.4009j \\ 0.1965 - 0.6057j & 0.9533 & 0.8981 \\ 0 & 0 & 0 \end{bmatrix}$$

$$\begin{bmatrix} 0 & 0 & 0 \\ 0 & 0 & 0 \\ 0 & 0 & 0 \\ 0.3776 - 0.1337j & 0.9412 & 0.8247 \\ 0.9163 & -0.2769 - 0.1934j & -0.3100 + 0.4731j \\ 0 & 0 & 0 \end{bmatrix}$$

$$\mathbf{S}_3 = \begin{bmatrix} 0.9752 & 0.9460 & 0.7399 \\ 0 & 0 & 0 \\ 0.0465 - 0.2134j & -0.2049 + 0.0750j & 0.6422 + 0.0888j \\ 0.0103 + 0.0351j & 0.1069 - 0.2146j & 0.0334 - 0.1768j \\ 0 & 0 & 0 \\ 0 & 0 & 0 \end{bmatrix}$$

$$\begin{bmatrix} -0.2545 + 0.1283j & -0.3400 - 0.5552j & 0.6774 \\ 0 & 0 & 0 \\ 0.8437 & 0.7240 & 0.1983 - 0.3280j \\ 0.3826 - 0.2459j & -0.1305 + 0.1869j & 0.0775 + 0.6231j \\ 0 & 0 & 0 \\ 0 & 0 & 0 \end{bmatrix}$$

Once again the codeword matrices do not span the whole signal space. In this case user 1 spans the subspace determined by frequencies 2, 3, and 6; user 2 spans the subspace corresponding to

frequencies 4 and 5; while user 3 spans the subspace implied by frequencies 1, 3, and 4. The water filling distribution that corresponds to each user's inverted channel problem can be observed by looking at the covariance matrices which are

$$\mathbf{R}^{(1)} = \text{diag}\{15.0089, 2.5918, 2.5918, 3.7487, 3.3680, 2.5918\}$$

$$\mathbf{R}^{(2)} = \text{diag}\{5.5547, 11.6265, 4.0123, 3.5041, 3.5041, 11.0805\}$$

$$\mathbf{R}^{(3)} = \text{diag}\{3.4527, 6.1543, 3.4527, 3.4527, 18.5505, , 7.3916\}$$

Overlap between users is also observed as follows: users 1 and 3 overlap in frequency 3, and users 2 and 3 overlap in frequency 4; both these overlaps are in minimum gain ratio dimension.

Next we look at the potential reduction in receiver complexity implied by the partitioning of the signal space that corresponds to the optimal codeword ensemble. Specifically, in a signal space spanned by N frequencies, each user requires in general, $2N$ real matched filters, each having $2N$ real coefficients. This implies $4N^2$ multiply operations per frame per user. However, because users can only overlap in at most one frequency one might expect, depending on the actual gain matrices that each of the L users will occupy on the order of N/L frequencies. This implies that only $2N/L$ real codewords are necessary and for each codeword only $2N/L$ real coefficients will be nonzero. Thus, complexity could be reduced by a factor on the order of L^2 per user receiver and L overall. We illustrate this interesting property with a numerical example obtained from simulations. Let us consider N dimensions and L users. We assume that user gain matrices are randomly perturbed identity matrices represented in the real notation as $\mathbf{\Lambda} = \text{diag}\{1 + \epsilon_1^{(\ell)}, 1 + \epsilon_1^{(\ell)}, \dots, 1 + \epsilon_N^{(\ell)}, 1 + \epsilon_N^{(\ell)}\}$ where $\epsilon_i^{(\ell)}$ is a uniform random number with $|\epsilon| \leq 0.1$. Uniform white background noise is also assumed.

For $N = 10$ and $L = 2, 3, 4, 5, 10, 20$ we have applied interference avoidance to a number of such randomly chosen systems and a plot of the average number of dimensions per user is provided in Figure 2. As a consequence of the fact that users overlap in only one frequency we note that the more users are present in the system, the fewer frequencies are spanned by each user – with the implied decrease in user receiver complexity with L .

7 Discussion and Conclusions

We have presented application of greedy interference avoidance to codeword optimization in the uplink of a CDMA system in which the channel between users and the base station are considered stable and known for the duration of the transmission. We note that in general, codeword optimization algorithms based on greedy interference avoidance are different from water filling procedures, although they yield codeword ensembles which maximize sum capacity and satisfy a simultaneous water filling condition [28]. We also prove that greedy interference avoidance monotonically increases sum capacity, an important property which was not mentioned in the previous

work on greedy interference avoidance [21, 22], although a similar property was proved in [24] for the MMSE algorithm for interference avoidance.

We illustrate the interference avoidance algorithms with some examples and look at properties of the optimal codeword ensembles generated. While these properties, which characterize the simultaneous water filling distribution, have been discovered independently by others [6, 16], we look at them from a user codeword perspective, rather than a transmit covariance matrix perspective. We mention the signal space partition corresponding to the optimal codeword ensemble which implies that user codeword matrices span distinct subspaces with potential overlap in at most one frequency. We argue that this property may imply a reduction in receiver complexity and provide also simulation results in corroboration.

We note that the use of uniform energy codewords which maximize sum capacity allows matched filters to be used as the optimal linear receivers [25–27]. In our context this implies a simple receiver structure consisting of a matched filter bank for each user ℓ and identical independent modulation of the M_ℓ symbol streams associated with user ℓ . Such receivers composed of many identical structures might be good candidates for integration. We also note that interference avoidance methods work with both real and complex channel models and can be used in generating complex codeword ensembles which maximize sum capacity in the presence of dispersive channels.

We close with some remarks about the general use of interference avoidance methods for codeword adaptation in CDMA systems. We would like to emphasize that interference avoidance provides distributed algorithms for codeword optimization in which users independently adjust codewords in response to changing patterns of interference. Unlike centralized optimization methods performed at the base station which require complete knowledge of the system, distributed codeword adaptation through interference avoidance requires only that each user know its associated channel and have access to the system covariance information³. While the mathematics behind interference avoidance allows for centralized processing as well, it is the distributed version of the algorithm which may prove useful in unlicensed/uncoordinated environments.

Interference avoidance can also be applied to fading channel scenarios [17, 18]. In such cases, the assumption of perfect channel knowledge made in the paper can be relaxed, and one can assume that the channel is either slowly varying, in which case channel estimates can be used for a relatively large number of transmission intervals, or that the average characteristics of the channel are known. These are reasonable assumptions for high data rate systems and environments with reduced degrees of mobility [8].

We conclude with the remark that in deciding which method is more useful from a practical standpoint – interference avoidance vs. iterative water filling – one needs to carefully weigh several

³Which can be accomplished through a feedback channel broadcast from the base for example.

factors. One can always apply iterative water filling [28] followed by an appropriate factorization of the transmit covariance matrix to obtain a set of codewords that can be used for transmission. In general these codewords will have different SINRs, and while they don't have any theoretical restrictions as they are not relevant from the perspective of sum capacity, the SINR is important in practice as it may affect receiver front end dynamic range, peak to average power ratios and thus quantization. Hence, from a practical standpoint, having uniform SINRs may be especially useful and attractive for integration purposes. Alternative algorithms for constructing optimal codewords with uniform SINR could also be employed [25, 26], and the ultimate decision needs to take into consideration all these facts.

Acknowledgment

The authors would like to acknowledge Prof. Michael Honig for his valuable suggestions and insights on the work presented in the paper. The authors are also grateful to Dr. Giuseppe Caire and to three anonymous reviewers for their useful comments and remarks on an earlier version of the paper.

References

- [1] J. A. C. Bingham. Multicarrier Modulation for Data Transmission: An Idea Whose Time Has Come. *IEEE Communications Magazine*, 28(5):5–14, May 1990.
- [2] R. S. Cheng and S. Verdú. Gaussian Multiaccess Channels with ISI: Capacity Region and Multiuser Water-Filling. *IEEE Transactions on Information Theory*, 39(3):773–785, May 1993.
- [3] J. I. Concha and S. Ulukus. Optimization of CDMA Signature Sequences in Multipath Channels. In *Proc. 53rd IEEE Vehicular Technology Conference – VTC'01*, volume 3, pages 1227–1239, Rhodes, Greece, May 2001.
- [4] T. M. Cover and J. A. Thomas. *Elements of Information Theory*. Wiley-Interscience, New York, NY, 1991.
- [5] S. N. Diggavi. Multiuser DMT: A Multiple Access Modulation Scheme. In *Proceedings 1996 IEEE Global Telecommunications Conference - GLOBECOM '96*, pages 1566 – 1570.
- [6] S. N. Diggavi. Properties of Sum-Capacity Achieving Solutions for Multiuser DMT. Private communication, October 2000.
- [7] T. Guess. Optimal Sequences for CDMA with Decision-Feedback Receivers. *IEEE Transactions on Information Theory*, 49(4):886–900, April 2003.
- [8] H. Hashemi. The Indoor Radio Propagation Channel. *Proceedings of the IEEE*, 81(7):943 – 968, July 1993.
- [9] S. Haykin. *Communication Systems*. Wiley, New York, NY, fourth edition, 2001.
- [10] J. L. Holsinger. Digital Communication Over Fixed Time-Continuous Channels With Memory - With Special Application to Telephone Channels. Technical Report 366, MIT - Lincoln Lab., 1964.
- [11] M. L. Honig, K. Steiglitz, and S. A. Norman. Optimization of Signal Sets for Partial-Response Response Channels - Part I: Numerical Techniques. *IEEE Transactions on Information Theory*, 37(5):1327–1341, September 1991.

- [12] R. A. Horn and C. A. Johnson. *Matrix Analysis*. Cambridge University Press, Cambridge, United Kingdom, 1985.
- [13] S. Kasturia, J. T. Aslanis, and J. M. Cioffi. Vector Coding For Partial Response Channels. *IEEE Transactions on Information Theory*, 36(4):741–762, July 1990.
- [14] J. W. Lechleider. The Optimum Combination of Block Codes and Receivers for Arbitrary Channels. *IEEE Transactions on Communications*, 38(3):615–621, May 1990.
- [15] A. W. Marshall and I. Olkin. *Inequalities: Theory of Majorization and its Applications*. Academic Press, Orlando, FL, 1979.
- [16] S. Ohno, P. Anghel, G. Giannakis, and Z. Luo. Multicarrier Multiple Access is Sum-Rate Optimal for Block Transmissions over Circulant ISI Channels. In *Proceedings 2002 IEEE International Conference on Communications – ICC’02*, volume 3, pages 1656–1660, May 2002.
- [17] D. C. Popescu. *Interference Avoidance for Wireless Systems*. PhD thesis, Rutgers University, Department of Electrical and Computer Engineering, 2002. Thesis Director: Prof. C. Rose.
- [18] D. C. Popescu and C. Rose. Fading Channels and Interference Avoidance. In *Proceedings 39th Allerton Conference on Communication, Control, and Computing*, pages 1073–1074, Monticello, IL, October 2001.
- [19] G. S. Rajappan and M. L. Honig. Signature Sequence Adaptation for DS-CDMA with Multipath. *IEEE Journal on Selected Areas in Communications*, 20(2):384–395, February 2002.
- [20] P. B. Rapajic and B. S. Vucetic. Linear Adaptive Transmitter-Receiver Structures for Asynchronous CDMA Systems. *European Transactions on Telecommunications*, 6(1):21 – 27, Jan. - Feb. 1995.
- [21] C. Rose. CDMA Codeword Optimization: Interference Avoidance and Convergence Via Class Warfare. *IEEE Transactions on Information Theory*, 47(6):2368–2382, September 2001.
- [22] C. Rose, S. Ulukus, and R. Yates. Wireless Systems and Interference Avoidance. *IEEE Transactions on Wireless Communications*, 1(3):415–428, July 2002.
- [23] S. Ulukus. *Power Control, Multiuser Detection and Interference Avoidance in CDMA Systems*. PhD thesis, Rutgers University, Department of Electrical and Computer Engineering, 1998. Thesis Director: Prof. R. D. Yates.
- [24] S. Ulukus and R. Yates. Iterative Construction of Optimum Signature Sequence Sets in Synchronous CDMA Systems. *IEEE Transactions on Information Theory*, 47(5):1989–1998, July 2001.
- [25] P. Viswanath and V. Anantharam. Optimal Sequences and Sum Capacity of Synchronous CDMA Systems. *IEEE Transactions on Information Theory*, 45(6):1984–1991, September 1999.
- [26] P. Viswanath and V. Anantharam. Optimal Sequences for CDMA Under Colored Noise: A Schur-Saddle Function Property. *IEEE Transactions on Information Theory*, 48(6):1295–1318, June 2002.
- [27] P. Viswanath, V. Anantharam, and D. Tse. Optimal Sequences, Power Control and Capacity of Spread Spectrum Systems with Multiuser Linear Receivers. *IEEE Transactions on Information Theory*, 45(6):1968–1983, September 1999.
- [28] W. Yu, W. Rhee, S. Boyd, and J. M. Cioffi. Iterative Water-Filling for Gaussian Vector Multiple Access Channels. In *Proceedings 2001 IEEE International Symposium on Information Theory - ISIT’01*, page 322, Washington, DC, June 2001. Submitted for journal publication.

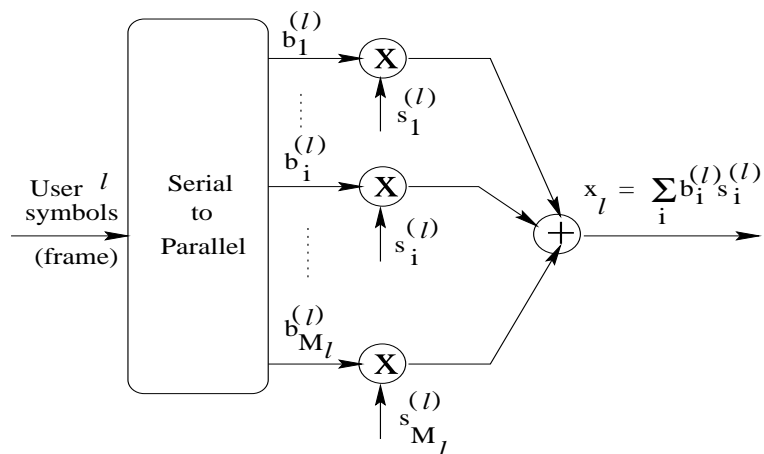

Figure 1: Multicode CDMA approach for sending frames of information. Each symbol in the frame is assigned a codeword (signature sequence) and the resulting signal x is a superposition of codewords scaled by their corresponding information symbols. Our problem will be to find optimal $\{s_{ij}\}$.

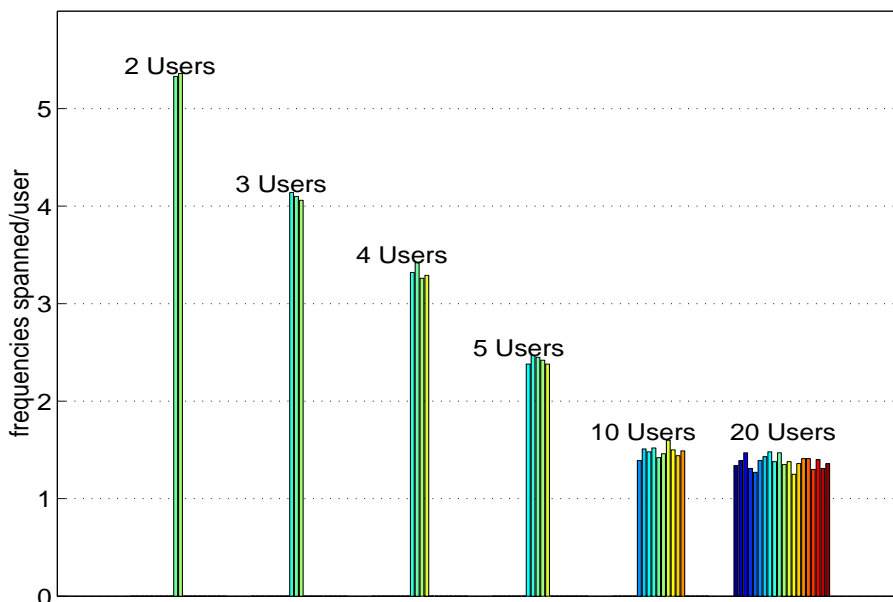

Figure 2: Average number of frequencies spanned for increasing number of users.